

**ZAPOROZHYE STATE MEDICAL UNIVERSITY**

Kaplaushenko A.G., Pryakhin O.R., Varinskiy B.A., Iurchenko I.A.,  
Shcherbak M.A., Samelyuk Yu.G., Kucheryavyi Yu.N., Hulina Yu.S.



**BASES OF IR, NMR, MASS-SPECTROSCOPY**

*Teaching and methodical manual  
for foreign student*

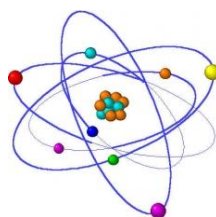

Zaporozhye, 2016

**ЗАПОРІЗЬКИЙ ДЕРЖАВНИЙ МЕДИЧНИЙ УНІВЕРСИТЕТ**

Каплаушенко А.Г., Пряхін О.Р., Варинський Б.О., Юрченко І.О.,

Щербак М.О., Самелюк Ю.Г., Кучерявий Ю.М., Гуліна Ю.С.

# **ОСНОВИ ІК-, ПМР-, МАСС-СПЕКТРОСКОПІЇ**

*Навчально-методичний посібник*

*для студентів англomовної форми навчання*

Запоріжжя, 2016

**UDC 543.4/5(075.8)=111**  
**BBC 24.4Я73**  
**B29**

**Authors:**

Kaplaushenko A.G., Pryakhin O.R., Varinskiy B.A., Iurchenko I.A.,  
Shcherbak M.A., Samelyuk Yu.G., Kucheryavii Yu.N., Hulina Yu.S.

**Reviewers:**

**Parchenko V.V.**, Dr.hab., Professor of the Department of Toxicology and  
Inorganic Chemistry, Zaporozhye State Medical University;

**Gladyshev V.V.**, Dr.hab, Professor, Head of the Department of Medicinal  
Preparations Technology, Zaporozhye State Medical University.

**Bases of ir, nmr, mass-spectroscopy:** teaching and methodical manual for  
foreign students / A.G. Kaplaushenko, O.R. Pryakhin, B.A. Varinskiy [et al.]. –  
Zaporozhye, 2016. – 70 p.

**Автори:**

Каплаушенко А.Г., Пряхін О.Р., Варинський Б.О., Юрченко І.О.,  
Щербак М.О., Самелюк Ю.Г., Кучерявий Ю.М., Гуліна Ю.С.

**Рецензенти:**

**Парченко В.В.**, професор кафедри токсикологічної та неорганічної хімії  
Запорізького державного медичного університету, д. фарм. н..

**Гладишев В.В.**, зав. кафедри технології ліків Запорізького державного  
медичного університету, д.фарм.н..

**Основи ІК-, ПМР-, МАСС-спектроскопії:** навчально-методичний  
посібник / А.Г. Каплаушенко, О.Р. Пряхін, Б.О. Варинський [та ін.]. –  
Запоріжжя, 2016. – 70 с.

Навчальний посібник розглянуто та затверджено:

Цикловою методичною комісією з фармацевтичних дисциплін  
(протокол №\_\_ від \_\_\_\_\_р.),  
Центральною методичною радою ЗДМУ  
(протокол №\_\_ від \_\_\_\_\_р.)

## **CONTENTS**

Introduction.....	5
Application of infrared spectroscopy in qualitative and quantitative analysis.....	6
Nuclear magnetic resonance. Theoretical bases and its application.....	30
Mass spectrometry. Theoretical bases and its application.....	35

## **Introduction**

IR-, NMR- and mass-spectrometry methods are leading to establish and confirm the structure of drugs. They are pharmacopoeia methods. The study of these methods is actually and it has a value in the preparation of pharmaceutical chemistry and pharmacognosy.

# **PART I. APPLICATION OF IR-SPECTROSCOPY IN QUALITATIVE AND QUANTITATIVE ANALYSIS**

## **Plan**

- Theoretical basis of the method.
- Technique of experiment
  - Equipment
    - Sources of radiation
    - Detectors
    - Spectrometers:
      - Systems with monochromators
      - Photometers
      - Multiplex Systems (Fourier- transformation)
  - Sample preparation
    - Gas samples
    - Solutions
    - Solid samples
- Identification
- Application pharmaceuticals in analysis.
- Quantitative analysis

## Theoretical basis of methods

Infrared spectroscopy is an important tool of chemistry. IR spectrometers are used in chemistry. IR spectrometers are used to gather information about the structure of substances and they are also an analytical tool for the study of purity of the compounds, confirmation of structure and the quantitative determination of substances.

The infrared region corresponds to electromagnetic radiation between visible and microwave area.



Pic. 1. The infrared region of the electromagnetic spectrum

Our today's lecture is devoted to research in the mid-IR absorption spectrum. These bands are associated with the excitation of vibrational energy levels.

There are electronic, vibrational and rotational energy transitions.

Vibrational IR-spectra have not all molecules, but only those who have a change of the electric dipole moment in oscillation.

HCl, HBr (present vibrational IR-spectra absorption)

H<sub>2</sub>, O<sub>2</sub>, Cl<sub>2</sub> (there are no vibrational IR -spectra absorption, because there is no change of the dipole moment).

The larger the mass of atoms connected, the lower the frequency that the connection will absorb.

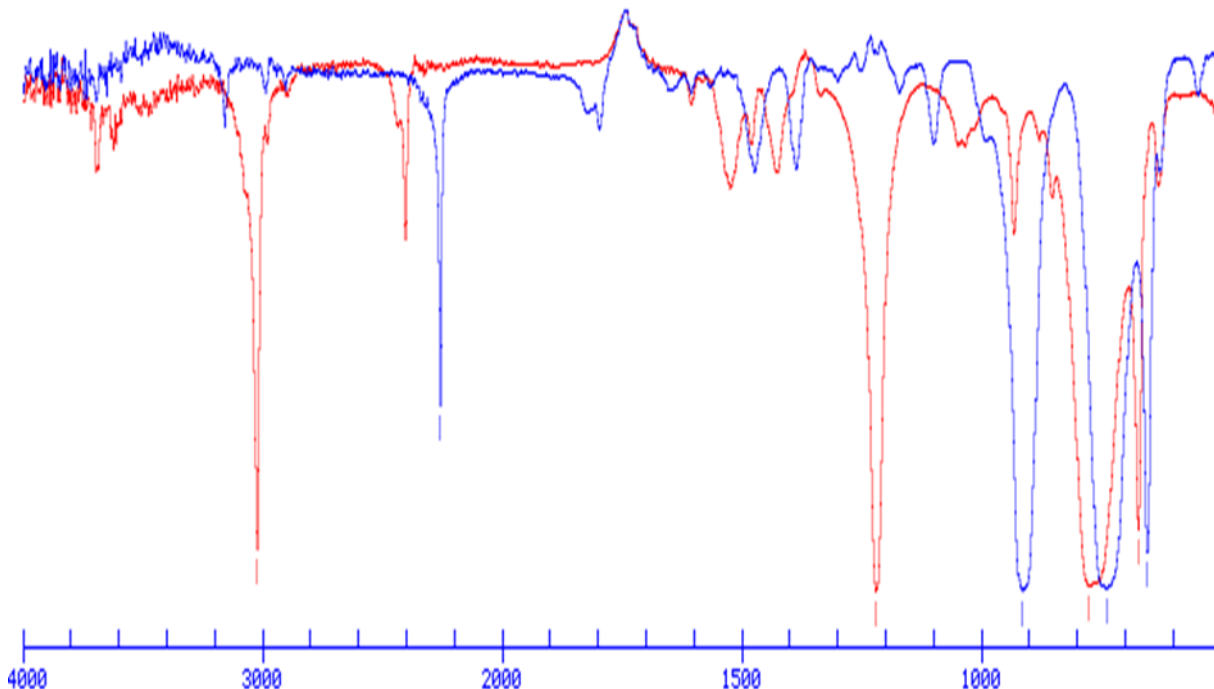

Red color - spectrum CHCl<sub>3</sub> chloroform.

Blue color - spectrum deuteriochloroform CDCl<sub>3</sub>.

All atoms are oscillate in polyatomic molecule.

The number of vibrational degrees of freedom in a non-linear molecule, consisting of N atoms as well  $3N-6$ , while the linear  $3N-5$ .

Complex picture of the oscillations in a polyatomic molecule is usually represented as a superposition of the so-called normal vibrations. The frequencies of the normal vibrations are characterized by the position of the bands in the infrared spectrum, and the amplitude of the oscillations is determined by the intensity of these bands.

The number of normal vibrations is equal to the number of vibrational degrees of freedom, and thus, the overall shape of the molecular vibrations is a superposition of  $3N-6$  (or  $3N-5$ ) normal vibrations.



For high symmetric molecules different vibrations may have the same frequency, resulting in a spectrum of molecules appears instead of a few bands of one - there is a degeneration.

There are stretching ( $\nu$ ) and deformation ( $\delta$ ) fluctuations.

Swing called valence, if there is a change of the bond lengths without substantially changing the angles between the bonds.

Fluctuations with a change of angles between the bonds are called *deformation*.

Vibrational spectra of polyatomic molecules is interpreted on the basis of the doctrine of molecular symmetry and group theory. Such information is extremely valuable for studying the structure of molecules. This information is a relatively small application to solve chemical-analytical problems. To solve these problems, we can use so-called *characteristic (group) frequency*. The bands at some frequencies can be brought into conformity with fluctuations in certain groups of atoms in a molecule. This explains the fact that the absorption band for these groups is present in the spectra of different molecules, regardless of the skeletal structure of the molecules. The emergence of these frequencies caused by the fact that the normal oscillations of the displacement of atoms is limited within a single functional group.

*Most of the group of frequencies* characterize functional groups containing hydrogen atoms or isolated double or triple bonds. Group of frequency located in the wavenumber domain above  $1300\text{ cm}^{-1}$ .

In the region *from  $400\text{ cm}^{-1}$  to  $1300\text{ cm}^{-1}$*  contains the vibrational frequency that can not clearly correlate with specific functional group, and because the mass forces and absorbing each fragment bonds are too close. This area contains important band for characteristic the molecule as a whole, so it is called *fingerprint region* or *area fingerprintovoy*.

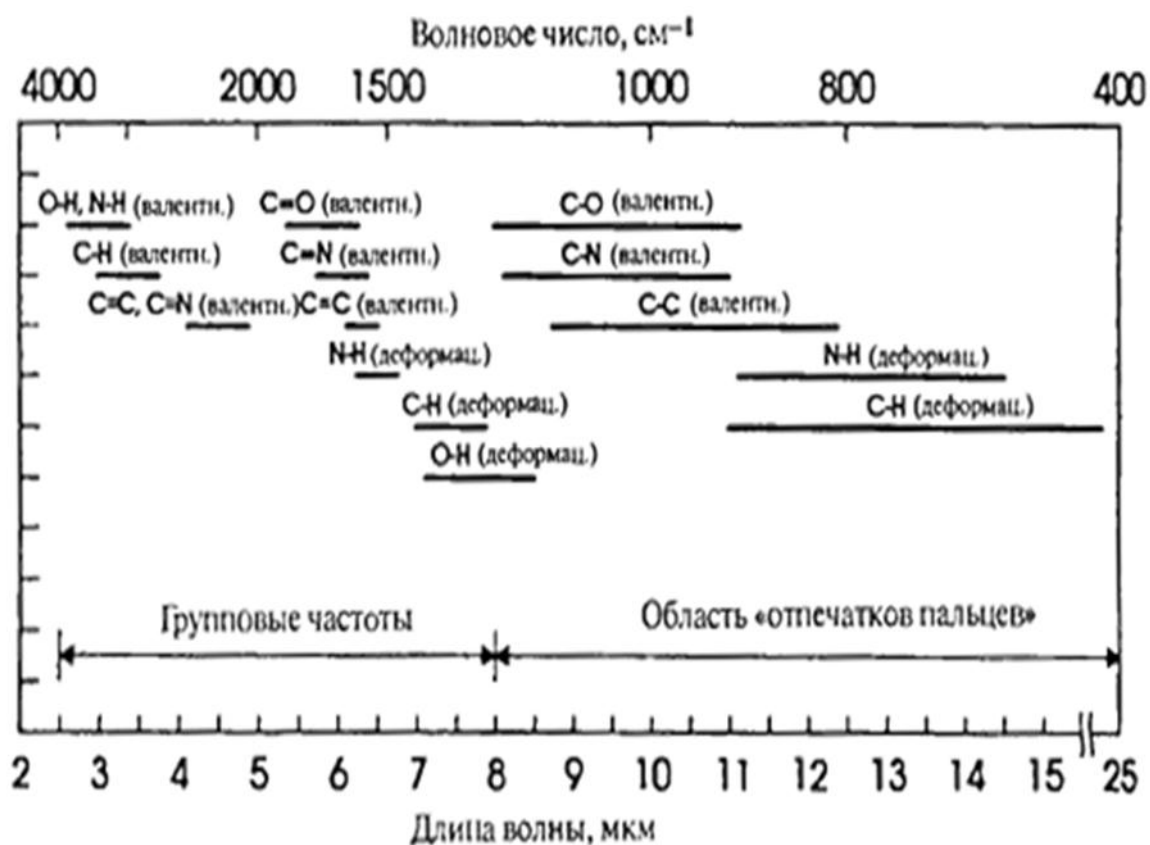

Pic. 2. Vibrational frequency and area of "fingerprints" of different functional groups

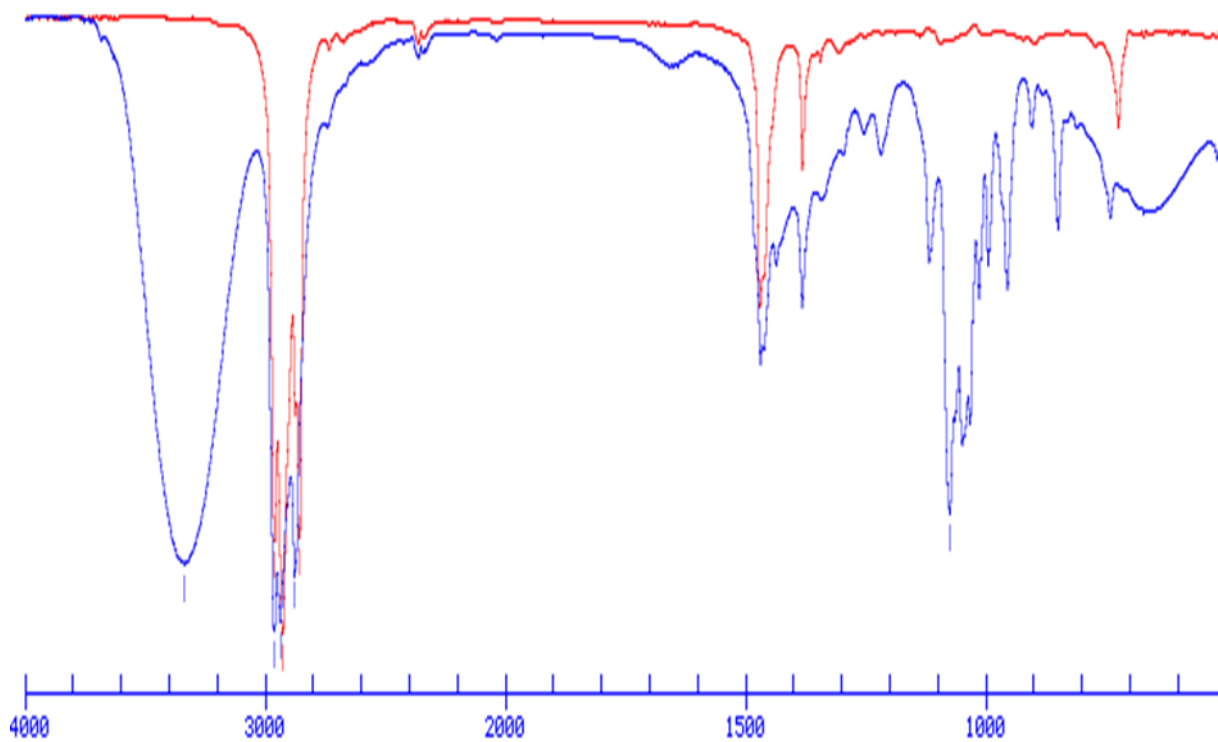

Red color - n-decane

Blue color - t-butanol.

In the area of 3600 cm<sup>-1</sup> - absorption band of alcoholic hydroxyl (OH stretching vibrations), absorption in the 3000-2800 cm<sup>-1</sup> due to the stretching vibrations of C-H.

(Ph. Eur. method 2.2.24)

Infrared Spectrometers are used to record spectra in the region 4000-650 cm<sup>-1</sup> (2.5-15.4 microns) or in some cases up to 200 cm<sup>-1</sup> (50 microns).

### **Equipment**

Spectrophotometers for recording spectra consist from the appropriate radiation source, a monochromator or interferometer and detector.

#### *Radiation sources*

As sources for the mid-IR region of the most commonly used silicon carbide rods ("globar") heated by electric current to about 1100 ° C.

If there is no need to scan the entire mid-IR then are used IR lasers. The intensity of radiation 100 times greater, but the available wavelengths of laser emission bands are determined.

### **Detectors**

In most cases, we can operate with detectors based on triglycine sulfate (TGS), which operate at room temperature.

There are also detectors by photoconductivity based on cadmium telluride and mercury (MCT). The last is much more sensitive and have a fast response, but can only operate at liquid nitrogen temperature.

TGS - in the mid- and far-IR range.

MCT - in several areas the average range.

## Systems with monochromators

In the last century, in 1950, one of the first double-beam infrared spectrometers appeared Perkin Elmer 21.

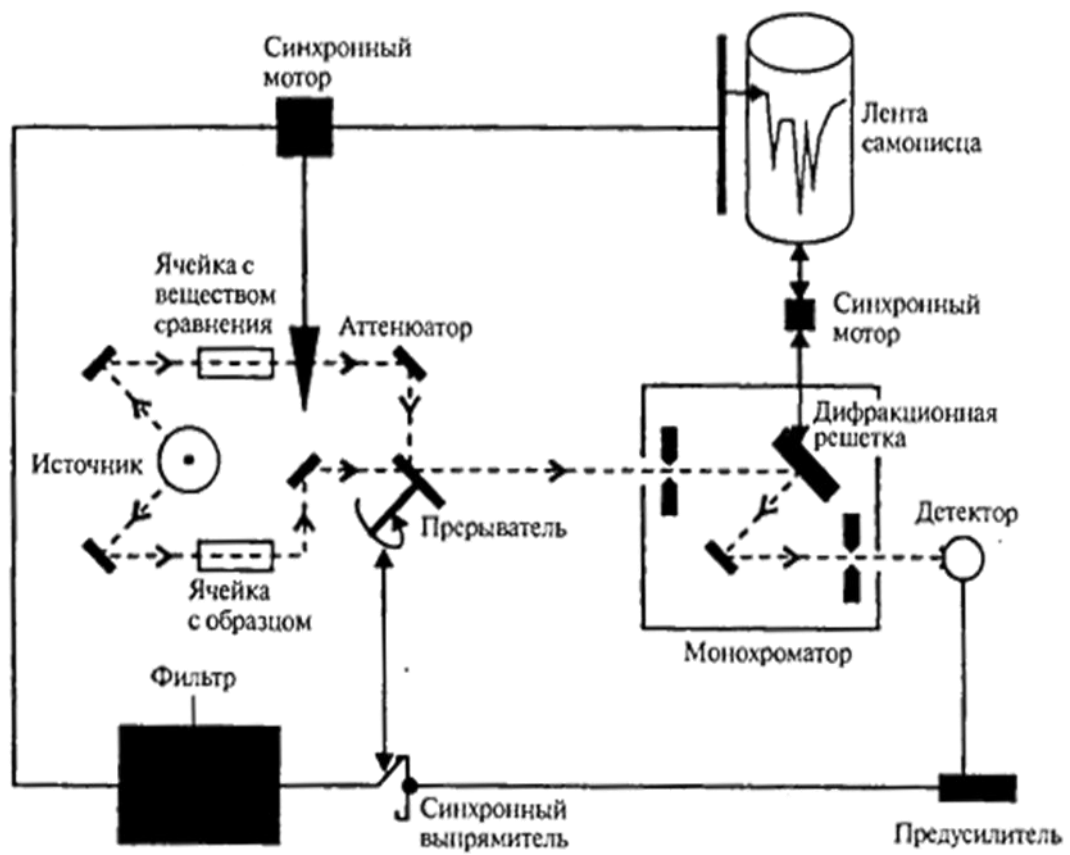

Pic. 3. The modern scheme of dual-beam infrared spectrometer

### Main components IR-spectrometer with a diffraction grating.

Usually devices have monochromator - rotatable prism or diffraction grating, on which there is expansion of the light waves of different lengths. The radiation passes through the sample to the detector and recorded the chart. Usually the spectrum is represented as a function of bandwidth. According to this attitude to the intensity of the transmitted light to the intensity incident on the sample.

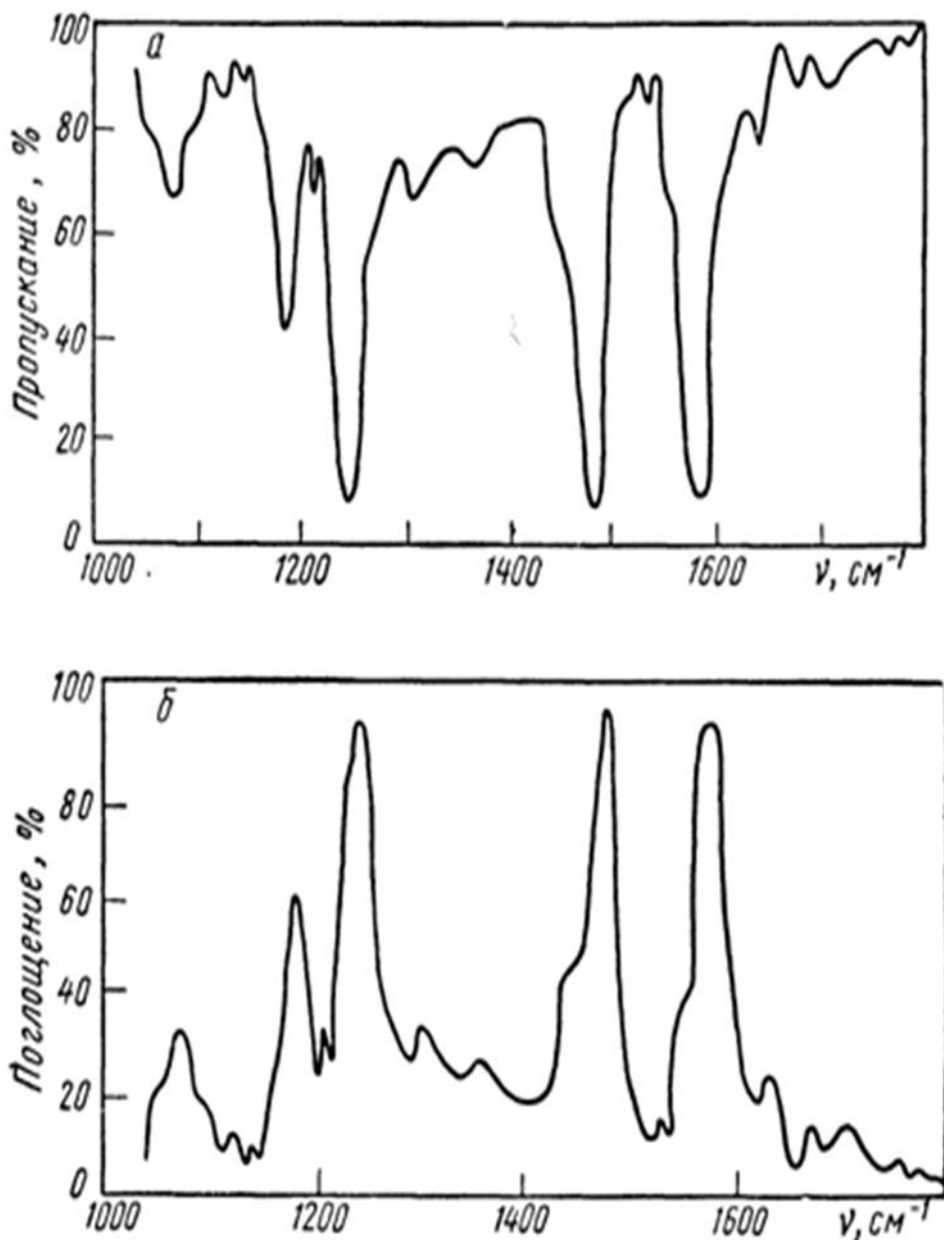

Pic. 4. The infrared absorption spectrum of diphenyl ether

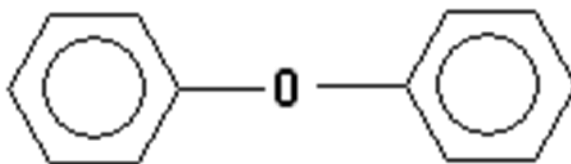

Pic. 5. Diphenyl Ethers

### **Photometer with filters**

In some cases, in the analysis of specific substances, used devices without substantial monochromatic light, but only with optical interference filters or cuvettes which filled of gas. Usually they are used for the routine quantitative determination of gases in the air.

### **Multiplex System (fourier-transformation)**

In spectrophotometers fourier-transformation is used polychromatic radiation and calculate the spectrum in a predetermined frequency domain by Fourier transformation of input data.

There are no monochromator in the Fourier technique. The sample is irradiated with all wavelengths at once, and then the information is processed by computer and issued spectrum. The gain in time. FT-IR gives spectrum in a second, and a monochromator is rotated for a long time, 10-15 minutes. Scoring also in the permit.

Radiation of each wavelength corresponds to a certain interference curve (interferogram). Interferogram depends on the optical path difference of the two beams and is the Fourier transform of the spectrum. Namely, the radiation energy distribution function of frequency.

The period of this function depends only on the wavelength. Curve obtained by using the interferometer. Radiation with a variety of frequencies - interference pattern - is the sum of the curves corresponding to each frequency (wavelength) in a spectrum. Fourier transformation allows to convert the interferogram into a spectrum, namely to allocate each frequency. This is a complex mathematical procedure is performed by a computer.

In this way Fourier spectrometer spectrum is obtained in 2 stages. First registered an interferogram, introduce to the imposition of the individual components of the spectrum. The frequencies of these components are associated with the wave numbers, and amplitude – intensity of the lines.

Then, using a computer carried decomposition interferogram into frequency components by *inverse Fourier transformation*.

The advantage of Fourier-spectroscopy is speed - the interferogram is recorded in computer memory within about one seconds.

The Fourier – spectroscopy there are no cracks and does not require focusing of the light.

The device has a *high aperture ratio* as it passes through all the radiation and *high resolution with simultaneous registration* of a large number of spectral lines.

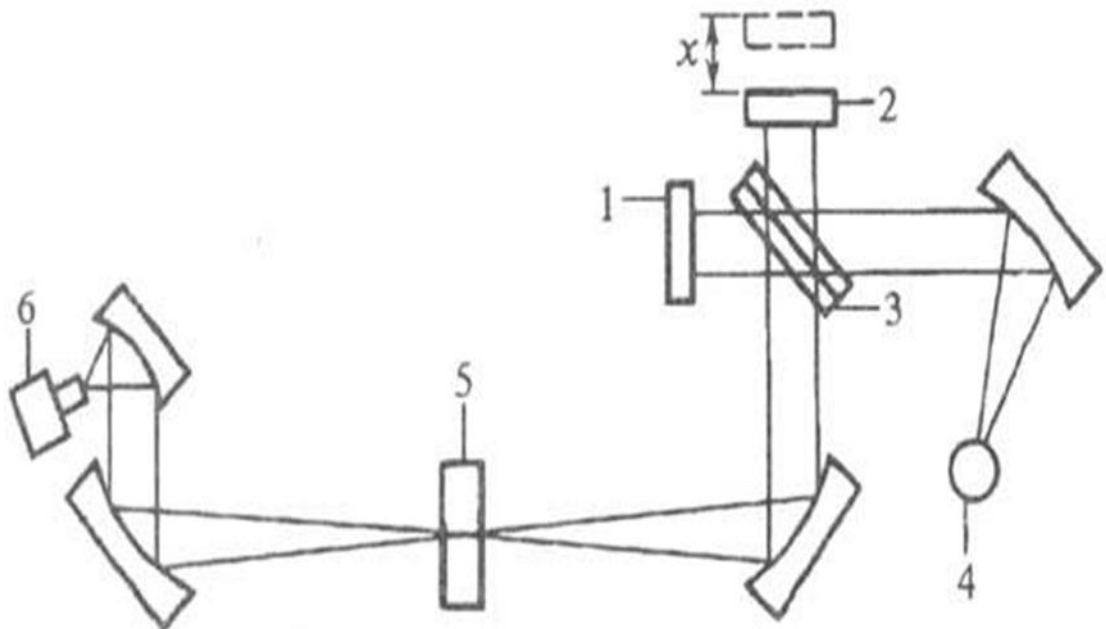

Pic.6. Optical scheme of the Fourier-spectrometer: 1 - fixed mirror of interferometer; 2 - movable mirror; 3 - beam-splitting plate; 4 - source of radiation; 5 - the sample; 6 - the radiation detector.

The sensitivity of analytical determinations on Fourier spectrometer usually in 100-1000 times higher performance in hundreds times more, the measurement error is much less than in the case of using dispersion devices. Limits of detection of a number of in-reach ng shares, and the use of a microscope allows to analyze the samples included in the dimensions of 10 x 10 mm<sup>2</sup>. With the FS can study the kinetics of the reactions taking place during approx. 1 ms.

The example allows us to understand that is permission

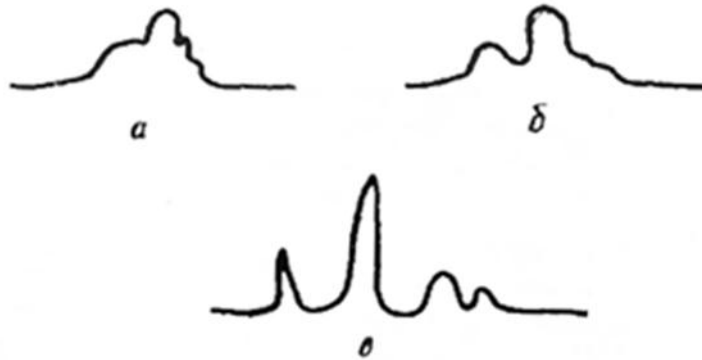

The same set of signals recorded with low (and) average, but not complete (b) and the high total (in) resolution.



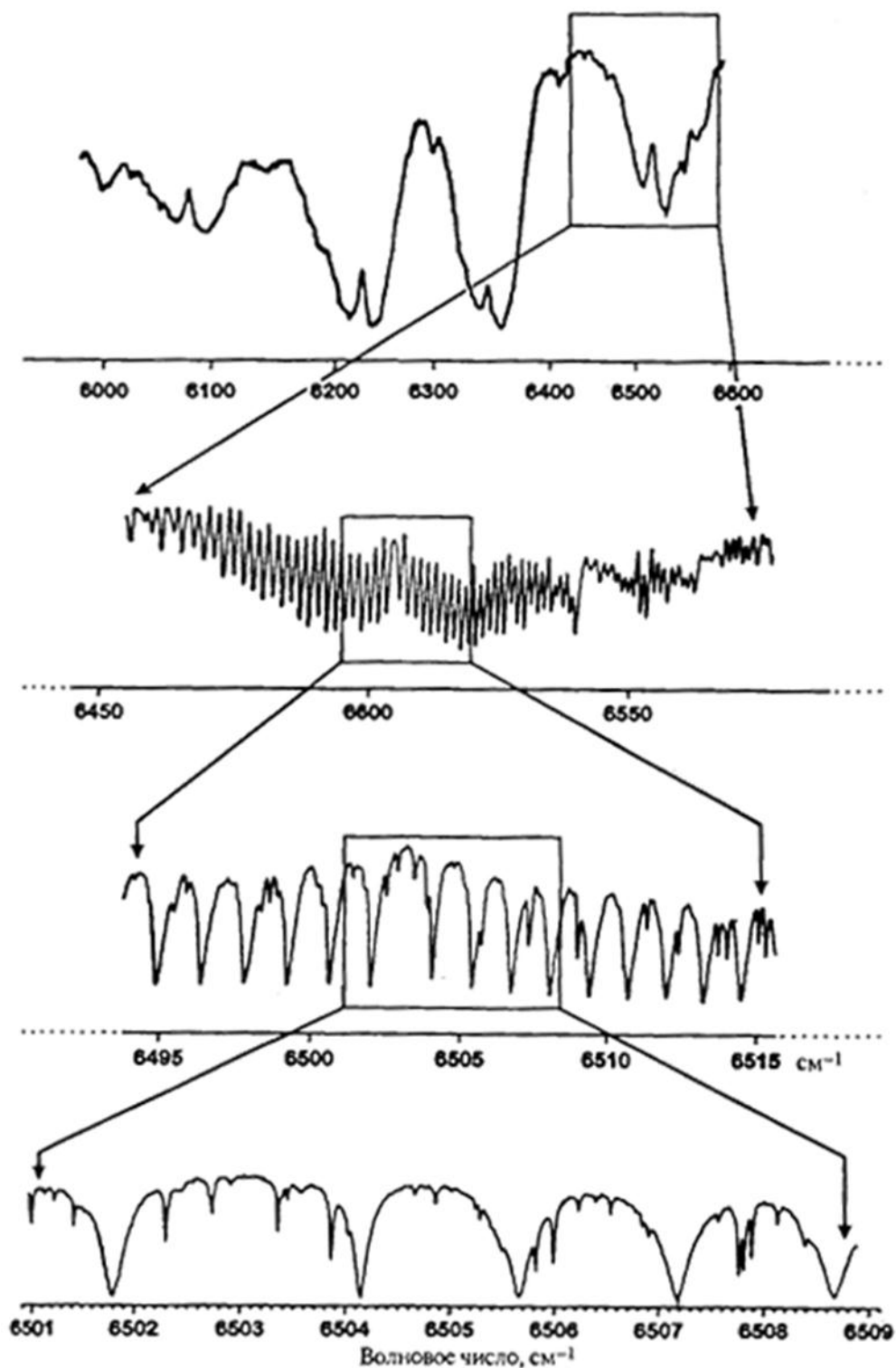

Pic. 7. Comparison of the spectra of gases obtained from the use of diffraction gratings with Fourier transformation. a - spektrometr with a diffraction grating; b - infrared spectrometer with Fourier-transformation; c – IR-spectrometer with Fourier-transformation; d - infrared spectrometer with Fourier-transformation.

### *Preparation of samples*

(According to the European Pharmacopoeia and HFC respectively)

For recording of transmission and absorption

Material was prepared by one of the following methods

### **Liquids**

Liquids are investigated in two ways: in the form of a membrane between two thin plates transparent for infrared radiation, or in a ditch of suitable thickness, is also transparent to infrared radiation.

#### *Liquids or solid substances in solution*

Preparing a solution in an appropriate solvent. Select the concentration and thickness of the layer ditch that will provide a satisfactory range. Generally, good results are obtained at a concentration of 10-100 g / l (10.1%) at a layer thickness of 0.5 -0.1 mm. The absorption solvent is offset location in the reference channel similar ditch that contains a solvent. If you are using FT-IR spectroscopy, the absorption spectrum is compensated by the record of solvent and the sample. Solvent Absorption corrected by a compensation factor, which is deducted using the software.

### **Solids**

Investigated by dispersing a solids in an appropriate solvent (suspension) or solid state (in the form of a pressed with halides alkali metal discs). Sometimes done a membrane of the molten mass and it is placed between two transparent plates for infrared radiation.

#### *A. suspension*

Triturate a small amount of of substance with a minimum quantity of liquid paraffin or other suitable liquid; 5-10 mg of substance is usually sufficient for suspension in one drop of liquid paraffin. Clamped suspension between two transparent plates for infrared radiation.

## *B. Disc*

2.1 mg of substance grind up with 300-400 mg of finely ground and dried potassium bromide or potassium chloride. This amount is usually enough for the disc manufacturing 10-15 mm diameter and obtaining spectrum of sufficient intensity. If the substance is hydrochloride, then it is recommended to mix with the potassium chloride. The mixture was thoroughly stirred, ensuring the necessary uniformity and pressed at 800 MPa.

For unstable substances under usual conditions or hygroscopic disc is pressed in vacuum. Different factors may be causing the formation of poor-quality disks such as insufficient or excessive rubbing, hygroscopicity, impurities in a dispersion medium or insufficient particle size reduction.

The disc is not suitable for use if in visual examination it is non-uniformly transparent or when passing at 2000  $\text{cm}^{-1}$  (5  $\mu\text{M}$ ) is less than 60% without compensation in the absence of a specific band of absorption substances (a requirement of the European Pharmacopoeia).

## **Gases**

Gases are tested in a ditch. It is transparent to infrared radiation and has a thickness about 100 mm.

### *Identification*

There are 2 approaches to the identification:

A comparison of the spectra (requires a standard sample or a reference spectrum). The most important region of the spectrum in this case is the area of "fingerprint".

Example:

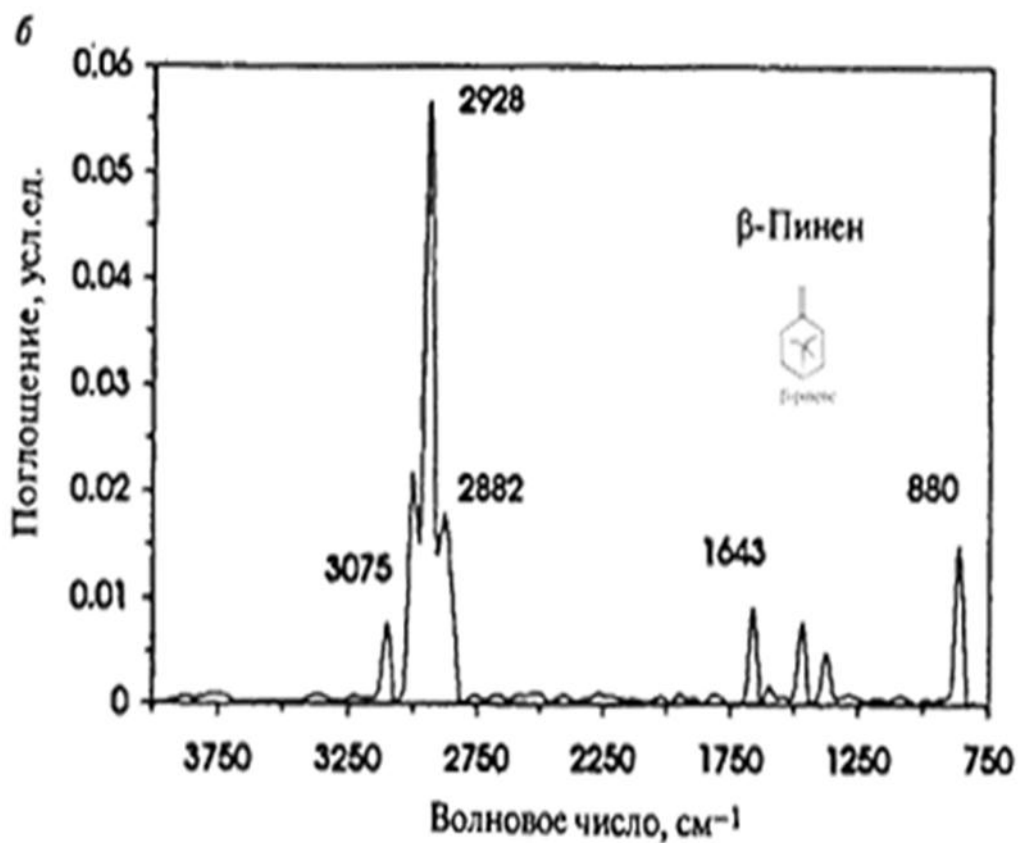
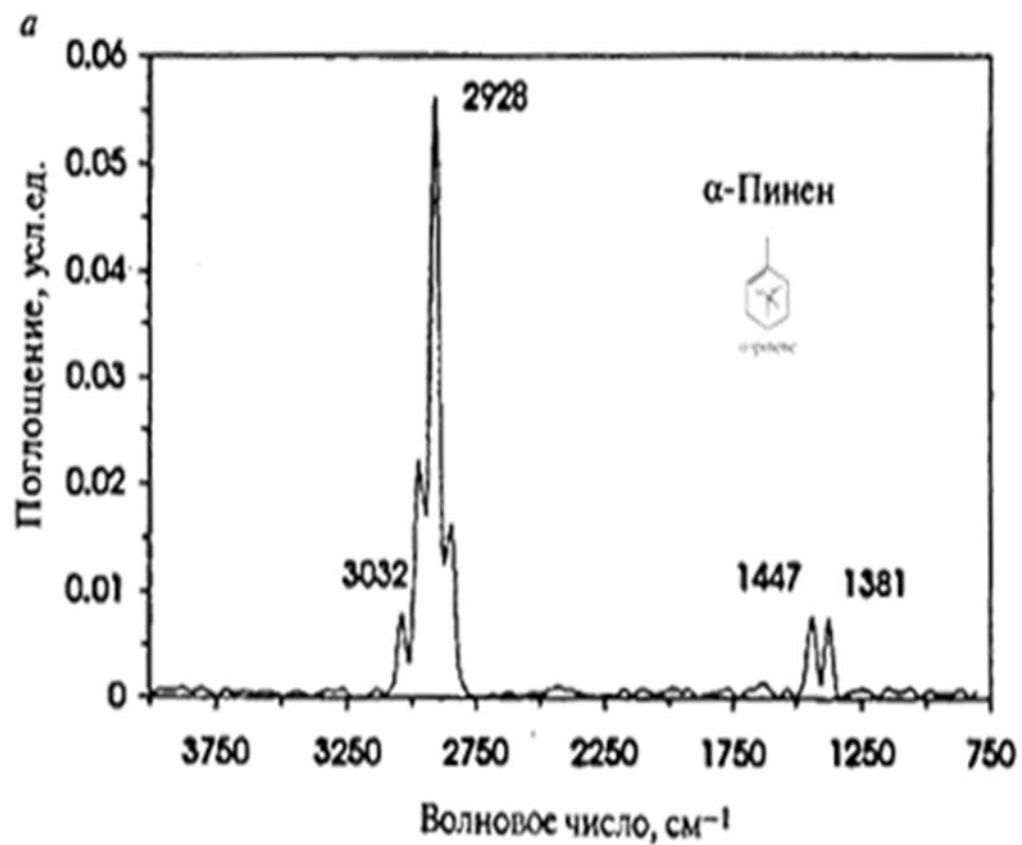

Pic. 8. The IR spectra of  $\alpha$ -pinene (a) and  $\beta$ -pinene, (b) in the group of frequencies and in a fingerprint.

Establishing the presence or absence of functional groups based on the detection of the characteristic group frequencies. Perhaps the two situations

The characteristic frequency of the group	Absent	Reliably supported by the absence of a functional group
	Present	It is no unambiguous evidence for the presence of this functional group, because it is possible the imposition of different frequency bands

For the first reference values for identification is often used so-called *Koltupa-card*, which indicated spectral regions the emergence of many characteristic frequencies and their possible assignment.

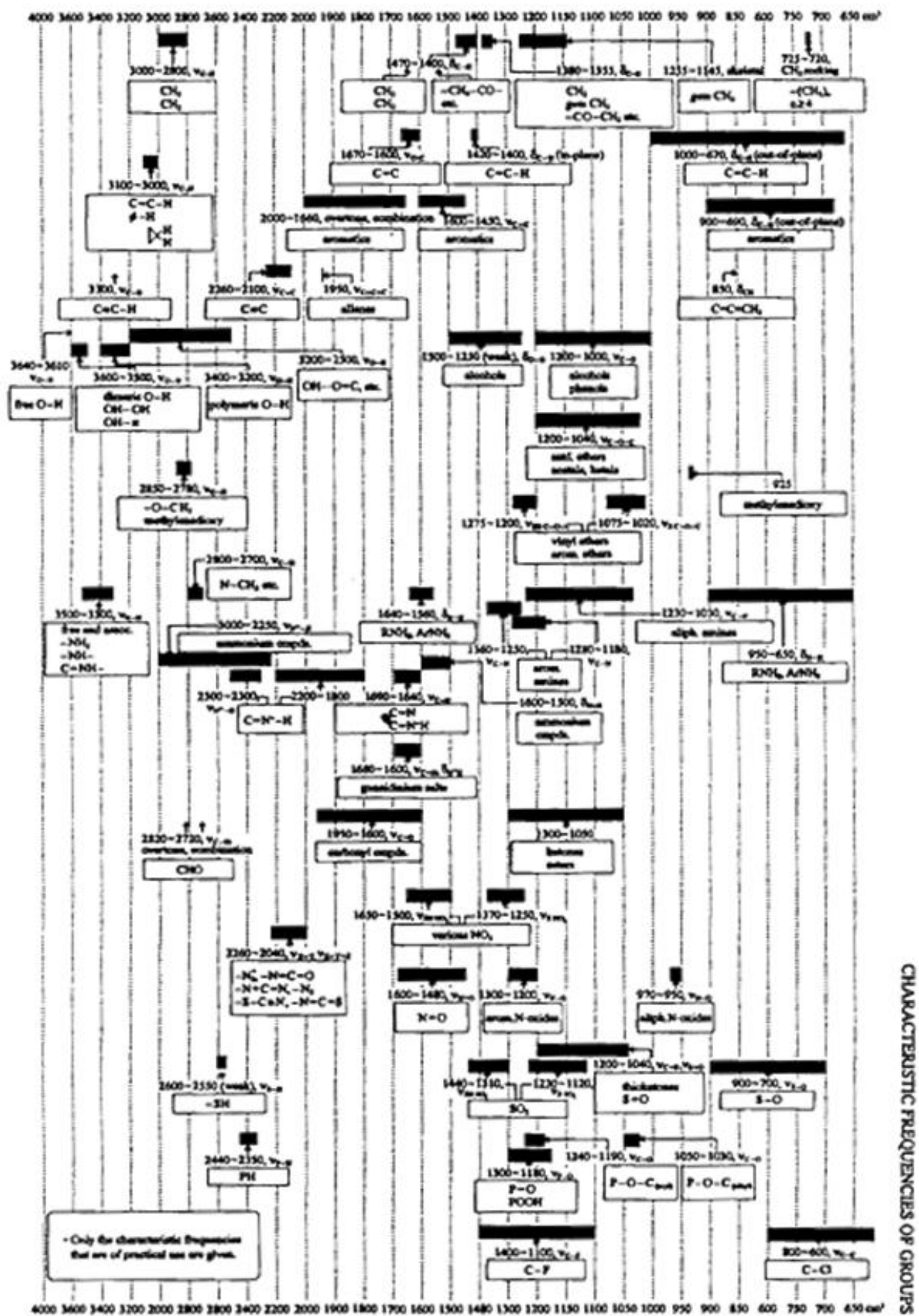

CHARACTERISTIC FREQUENCIES OF GROUPS

Pic. 9. The characteristic frequency

Identification according to the European Pharmacopoeia and consequently HFC conducted in two ways according to the first approach, namely a comparison of the spectra.

Using the standard samples.

Prepare the standard samples and test substances in identical conditions. Minimums passing (absorption maxima) of the substance in position and relative value should correspond to those of a standard sample.

Using the reference spectra.

Record the spectrum of the test substance and on top of it absorption band of polystyrene membrane. compares 2 spectrums - reference and analyzed, and the absorption band of polystyrene membrane at three wavelengths (3.51 microns, 6.25 microns, 9.72 microns). Provisions significant bands in the spectrum must fit within the 0.5% of the wavenumber scale. The ratio of intensities of bands both of spectra should be consistent with each other.

To is possible as well identify individual substances as components of mixtures (see. examples).

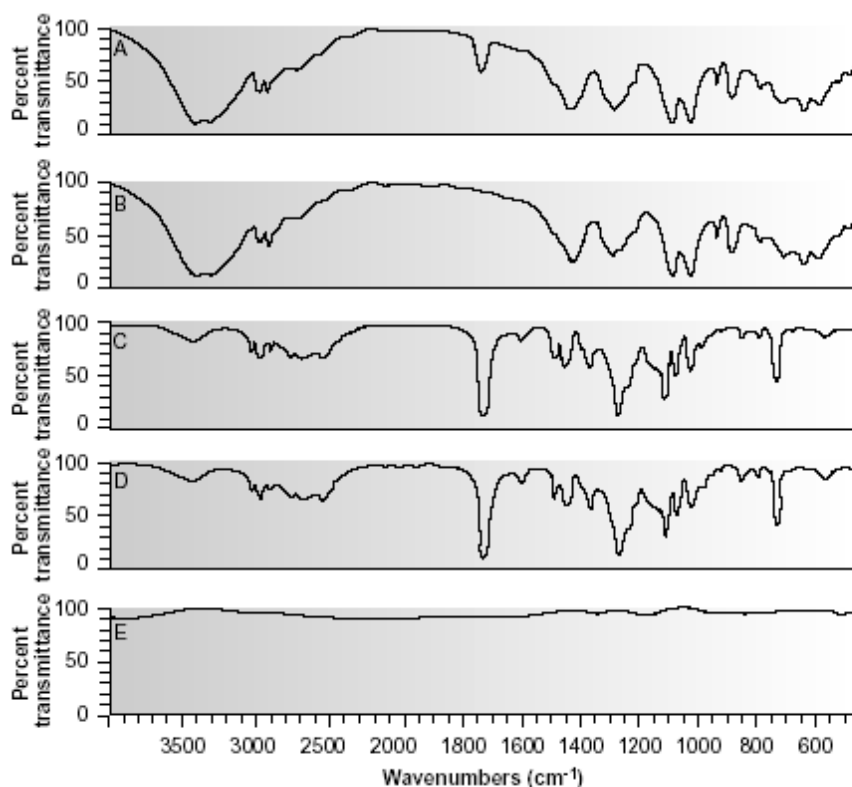

Spectral research in analysis of a mixture of mannitol and cocaine hydrochloride. a) IR-spectrum of the mixture, b) mannitol spectrum library, c) subtracting the result of IR-spectrum of a mixture of mannitol, d) IR-spectrum library cocaine hydrochloride, e) the result of subtracting spectrum of cocaine hydrochloride from the remaining spectrum.

Use of pharmaceuticals in the analysis (examples)

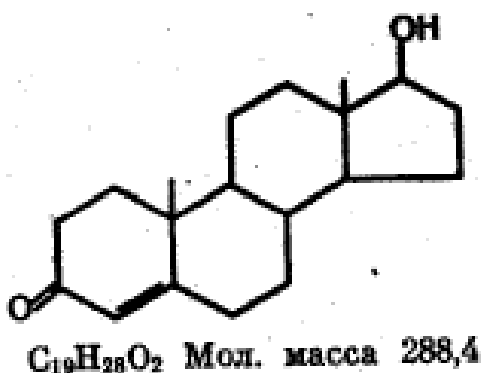

Pic. 10. Testosterone



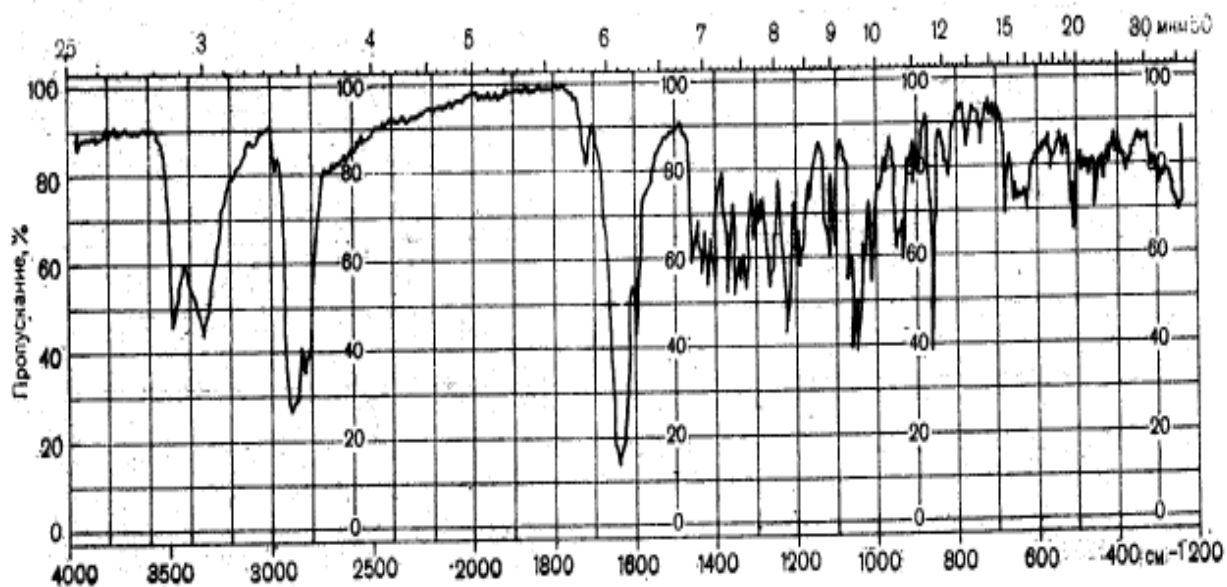

Pic. 11. IR-spectrum of testosterone in potassium bromide

17Beta-HYDROXYANDROST-4-EN-3-ONE  
INFRARED SPECTRUM

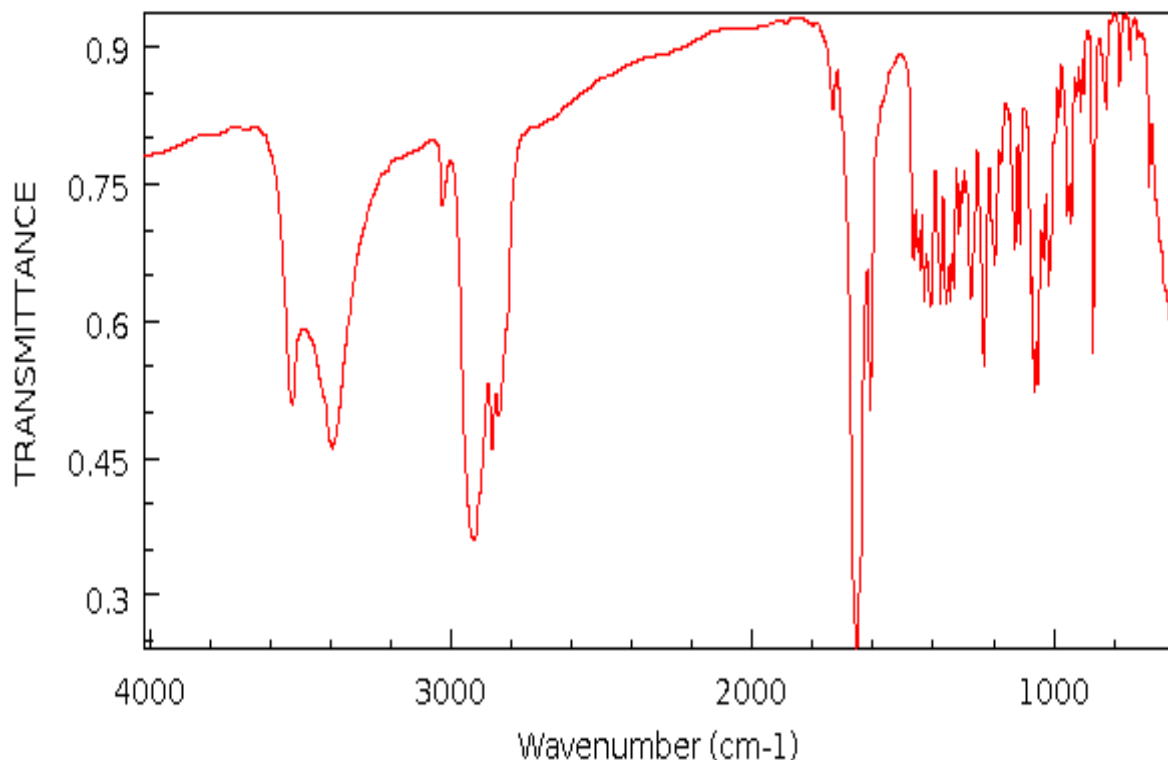

NIST Chemistry WebBook (<http://webbook.nist.gov/chemistry>)

Pic. 12. The reference spectrum (taken from the database of NIST)

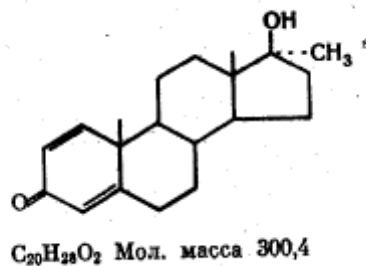

Fig. 13. Methandrostenolone

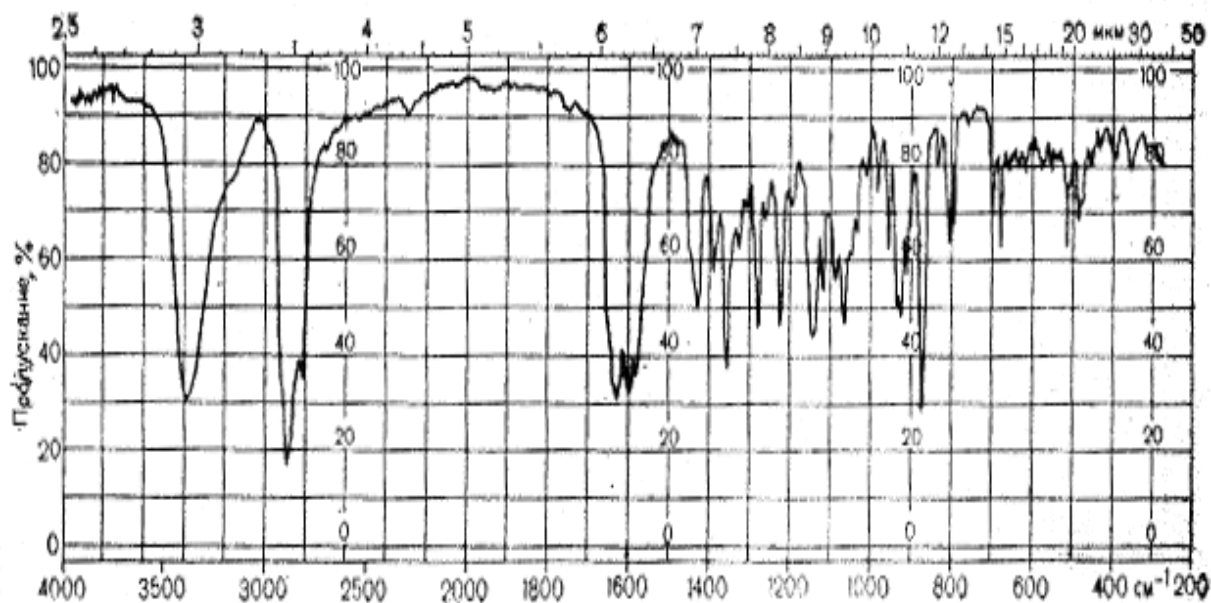

Fig. 14. IR spectrum of methandrostenolone in potassium bromide

In both preparations can distinguish one characteristic absorption bands) carbonyl, 2) CH<sub>2</sub>, 3) hydroxy.

In the area of 3600 cm<sup>-1</sup> - absorption band of alcoholic hydroxyl (OH stretching vibrations), absorption in the region 3000-2800 cm<sup>-1</sup> due to the stretching vibrations of C-H, 1580 -1900 cm<sup>-1</sup> (stretching characteristic vibrations groups of the C = O).

In the "fingerprint" there are significant differences.

In pharmacopoeias of different countries IR-spectroscopy is used to identify various drugs.

Collection	The number of spectrums	Comment
Sadtler	160 000	part FT-IR
<b>Sadtler vapor phase</b>	9 200	<b>FT-IR</b>
Canadian Scientific Numerical Database Service	166000	
НТЦ ХИ при НИОХ СО РАН	Over 70000	full spectra, about 50,000 structures
Aldrich-Nicolet	17 000	FT-IR
Sigma-Nicolet	10 600	---
Aldrich vapor phase	5 000	---
NIST/EPA vapor phase	5 244	---
NIMCR Japan	46 400	---
SpecInfo	22 600	17,000 full spectrums, 6600 provisions of the bands
Coblentz Society	10 500	4 400 full spectrums
IRDC Japan	19 000	wavelengths and intensities of the absorption bands
Sprouse Scientific	Some small collections	---

## Quantitative determination of the IR spectra

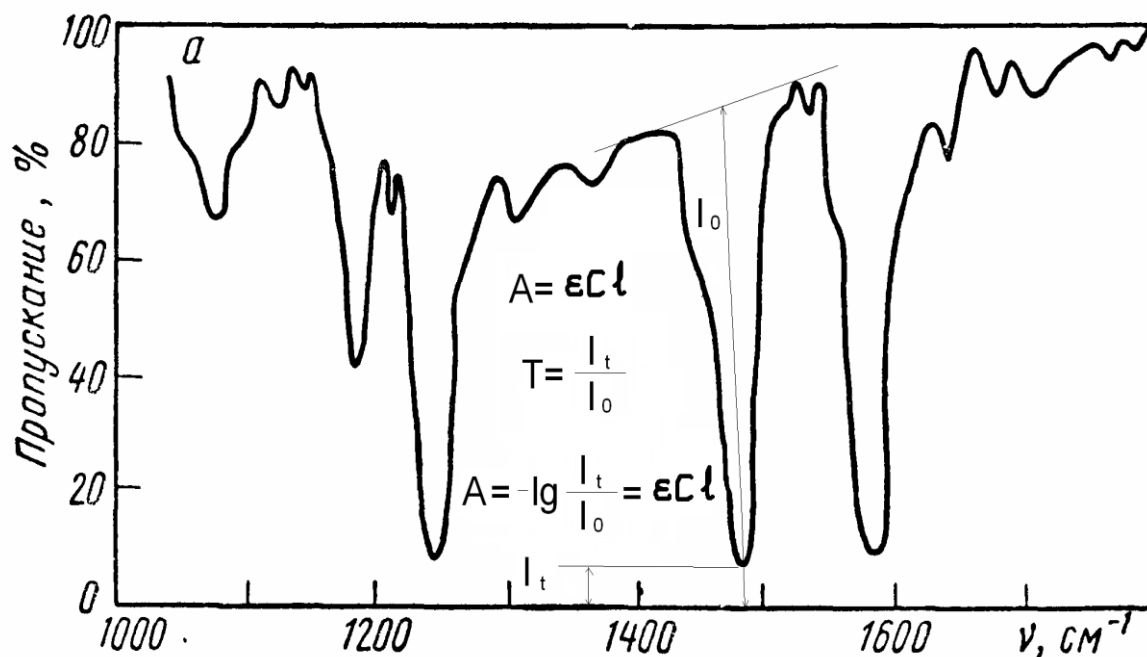

Quantitative analysis based on light absorption in the infrared range, although important, but it is much less used than with a UV / visible range. In the case of infrared radiation more often are instrumental deviations from Beer's law. Because the bands of infrared absorption are narrower, the deviation due to the lack of monochromatic radiation are more important. Besides infrared radiation sources are less powerful than the ultraviolet and visible region, so obtaining a directional radiation is a problem.

A possible difference in thickness of the layer of the sample and the standards, when the thin membranes are used or KBr tablet, is also a problem. Although the internal standard can be used to correct for differences in the thickness of the layer.

Finally, the definition of 100% transmittance  $T$  ( $A = 0$  - absorption) of the base line is usually difficult, because the optical properties of the ditch of the inorganic salts can vary significantly with wavelength due to contamination. This

problem can be minimized with respect to the definition of absorption to the baseline established by the absorption band.

The European Pharmacopoeia has an article that describes the research in the near-infrared diapason (Ph. Eur. Method 2.2.40) of 780 nm to 2500 nm (12 800 cm<sup>-1</sup> to 4000 cm<sup>-1</sup>).

## **PART II. NUCLEAR MAGNETIC RESONANCE. THEORETICAL FOUNDATIONS AND ITS APPLICATION**

### **Plan**

- Theoretical foundations of the method.
- Experimental technique
  - Equipment. Scheme of NMR spectrometer.
    - Sources of radiation
    - Detectors
  - Spectrometers:
    - Sample preparation
    - Gas samples
    - Solutions
    - Solid samples
- Identification
- Application in the analysis of pharmaceuticals.
- Quantitative analysis

## Theoretical basis of the method

The first successful experiments on nuclear magnetic resonance were held at the end of 1945 by two independent groups of researchers led by Purcell and Bloch.

NMR spectroscopy is used to determine the structure of molecules, study the interaction between the molecules, the kinetics and dynamics of molecules, determining the composition of biological and synthetic solutions and composites. Method equally effectively applicable to low molecular weight organic molecules and metabolites, proteins and natural products average size and biomolecules having a molecular weight of tens of kDa.

NMR effectively complements other analytical methods such as X-ray spectroscopy, crystallography and mass spectrometry. The advantage of NMR is the unique ability of the non-destructive quantitative analysis of molecules in solutions, solid state, and the study of biological fluids.

If the system of nuclei which have magnetic moments, placed in an external magnetic field, they will be exposed to forces that orient their magnetic axis in the direction of this field. Under certain conditions, specific to the nucleus, the magnetic moments of nuclei will resonantly absorb energy from the alternating magnetic field, frequency lies in the radio changes. This absorption leads to a nuclear magnetic resonance (NMR).

The spin of the nucleus is equal to  $\frac{1}{2}$ , corresponding to the two possible orientations the vector of the magnetic moment of the nucleus in a magnetic field - on the field ( $m_I = \frac{1}{2}$ ) and against the field ( $m_I = -\frac{1}{2}$ ); while the state  $m_I = -\frac{1}{2}$  has in an external field slightly higher energy than the state  $m_I = \frac{1}{2}$ . The energy of transition between these states is

$$\Delta E = 2\mu H_0,$$

$\mu$  - magnetic moment of the nucleus;

$H_0$  - strength of the external magnetic field.

The number of particles in each of these levels can be determined by the distribution law of Boltzmann:

$$N_1/N_2 = \exp\left(-\frac{E_1 - E_2}{kT}\right) = \exp\left(-\frac{2\mu H_0}{kT}\right), \quad (1)$$

where  $N_1$  and  $N_2$  - the number of particles on the upper and lower energy levels and having energy  $E_1$  and  $E_2$  respectively.

The calculation according to the equation (1) shows that the ratio  $N_1 / N_2$  at normal temperatures begins to differ from unity only in the sixth decimal place. Thus, at ordinary temperature population both levels will be about the same with very slight predominance state having lower energy. If such system, which is in a magnetic field strength  $H_0$ , placed in an alternating electromagnetic field with a frequency  $\nu_0$ , the energy  $h\nu_0$  quantum coincides with the energy transition  $2\mu H_0$ , that is

$$h\nu_0 = 2\mu H_0, \quad (2)$$

then due to the absorption the energy of nucleus of the field with the lowest energy level will go at the top.

The magnetic field  $H_0$

Scheme of NMR spectrometer

Equation (2) shows that a resonance absorption can be achieved either by changing a tension of the magnetic field strength  $H_0$  at a constant frequency, or frequency variation superimposed in a static magnetic field.

The advantage of conventionally used devices in which the resonance conditions are achieved by changing the magnetic field strength is the convenience and ease of operation, because the frequency is easier to stabilize than the field.



Sometimes prefer to change the frequency at a constant field, because it allows you to cover a wider range of energy and other tasks.

The corresponding frequencies can be found by sequential search or resonant states (continuous spectrometry), or by the simultaneous excitation of all the possible multi-frequency pulse with subsequent of computer processing of reducing the emission-free induction, which is produced by the system when returning to the ground state (pulse spectrometry).

According to recommendations of HFCs are used NMR - spectrometers which operate at a frequency of at least 60 MHz 'N. Nowadays manufacturing companies offer superconducting magnets ranging from 400 MHz and 1 GHz ending.

Schematic diagram of the spectrometer to observe the NMR is shown in picture 15.

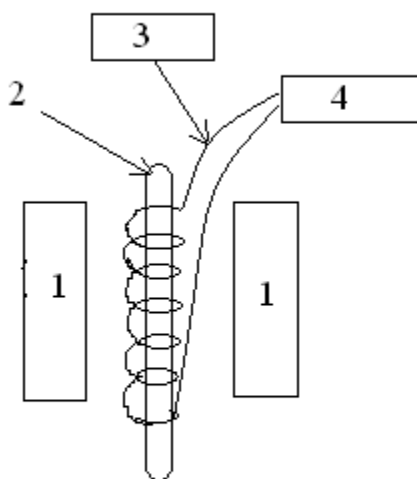

Pic 15. Scheme of NMR spectrometer. 1 - a magnet; 2 - test substance; 3 - detectors; 4 - generator of radiofrequency.

For research by NMR-spectroscopy usually substance is dissolved in an appropriate solvent (however, NMR analysis can be performed in the solid phase). For analysis requires ~ 10-20 mg of sample. The mixed solution was placed in ampoule volume ~ 0.5 ml and a diameter of 5 mm.

The choice of solvent is determined by the solubility of the analyte and the most complete separation signals resonance of substance and solvent, if the latter contains nucleus, which carried out the registration of the NMR spectrum. For analysis is useful to use deuterated solvents as deuterium does not give a signal in spectrum of PMR.

Ampoule with the test substance is placed in coil of a radio-frequency generator which is located between the poles of an electromagnet.

Protons in a magnetic field instantaneously oriented in the field  $H_0$  (like a small bar magnet). For the first moment after making a sample number of nuclei, oriented along the field and against the field, the same (50% to 50%). As a result of the exchange of energy between the nuclei systems ("spins") and their environment ("bars") the number of the lower energy levels nuclei quickly increases to a value slightly greater than 50%.

Protons, which oriented along the field, are in a lower energy state than protons, which oriented opposite to the magnetic field.

In devices with a stabilized frequency and alternating magnetic field change in the magnetic induction a generator is carried out. When the condition is done (2), that is in the absorption of field energy, the detector detects a change in voltage in the circuit, which is recorded as a signal on the recorder or observed on the oscilloscope screen.

NMR method allows to solve important issues of physical and chemical analysis:

- Identification of organic compounds. Determination and confirmation of the structure (structural analysis). Qualitative analysis of complex mixtures;
- Quantitative analysis of the organic compounds in complex mixtures, usually with the use of internal standards. The method is not destructive, allows measurements using a single spectrum, does not require pre-calibration;
- Study dynamic equilibrium of conformational reactions, tautomerism, inter- and intramolecular reactions etc.;
- The study of complex formations. Methods are being developed obtaining real-dimensional image of the object by means of NMR (Nuclear Magnetic Resonance microscopy). This is a result of recording the NMR spectrum when applied to a sample field gradient. To improve the signal-to-noise ratio in NMR instruments used pulse Fourier spectroscopy.

A limitation of NMR spectroscopy as an analytical method is its lower sensitivity, so it is difficult to measure small values of the concentration of substances.

### **Qualitative analysis and structural researches by NMR method**

According to tabulated values or resonance shifts or according to the pre-calibration is possible to establish the existence of certain atomic groups in the investigated molecule, that is get information about its structure, and the peak area to determine the number of nuclei.

Application of NMR allowed to establish the structure of many complex compounds. This is one of the basic methods in organic chemistry

research and coordination chemistry. NMR method also investigated the structure of crystals, the kinetics of fast reactions and many other properties of the substance and the characteristics of reactions.

### **Quantitative analysis NMR method.**

At quantitative analysis of solutions the peak area of the can be used as a method to measure the concentration of the calibration curve or method of additives. Known as a technique in which the calibration curve reflects the concentration dependence of the chemical shift.

One of the most important methods based on nuclear magnetic resonance is spectrometry  $^1\text{H}$  - magnetic resonance spectroscopy of proton (PMR).

### **Interpretation of NMR spectra**

The main characteristics of the NMR spectra are

- chemical shift,
- multiplicity,
- constant spin - spin interaction;
- resonance signal area.

These characteristics depend on the chemical environment of the nucleus or nuclei groups, the number of neighboring nuclei having a magnetic moment of their relative location, and the number of nuclei analyzed in various structural fragments of molecules.

The number of groups of signals indicate how many of nonequivalent varieties of protons have in the molecule.

For example:

The position of signal on the abscissa - the chemical shift depend on the chemical environment of the proton.

The difference of position of protons signal and the position of the standard signal is called the chemical shift  $\delta$  of the proton.

As standard the most commonly used standard tetramethylsilane (TMS)  $\text{Si}(\text{CH}_3)_4$ . Recording NMR spectra carried out in such a way that  $H_0$  is increased from left to right. At the same time the chemical shift of signal TMS taken as zero, and is registered in the strongest field (right-hand side of the spectrum).

With increasing electronegativity of the atom, which is located near the absorbing proton, then  $\delta$  is greater.

For example:

The intensity of the signals indicates the relative content of each type of protons in the molecule.

For example:

In the spectrum of n-propane peak intensities are related to each other as 3:1 in according with the number of methylene group in H (2) and a 2-methyl group (6).

Splitting of signals to multiple closely spaced peaks. This splitting is a consequence of the interaction of the protons, which are considered, with other non-equivalent protons (or other nuclei with odd numbers).

There are doublets, triplets and quartets.

In a first approximation, multiplicity of the proton is equal to  $n + 1$ ,

n-number of protons which situated in adjacent with carbon atom (the atom vicinal).

In other words, the multiplicity is = the signal from proton + signals induced other protons.

Line of any multiplet will depend from the adjacent lines of the same multiplet at one and the same number of hertz. The numerical value of this distance is called the spin-spin interaction and marked «J».

You can make a few generalizations for interpreting NMR spectra:

For chemically equivalent nuclei is not observed splitting of the NMR signals.

If the nucleus is split at only one group of the  $N$  equivalent nuclei of spin  $I$ , then a number of components is equal multiplet  $2N * I + 1$  and the intensity ratio of the component are given the coefficient values of members in the binomial expansion of  $(a + b)^N$ .

Multiplet components are arranged symmetrically about the center of gravity multiplet, whose position in the NMR spectrum coincides with the value of the chemical shift of nuclei (or groups of cores).

The basic rules of the interpretation of the spectra:

- The number of non-equivalent groups of protons is determined by the number of signals;
- The number of interacting nuclei is determined by the multiplicity signals;
- Constants of the spin-spin interaction is determined by the distance between the components of multiplets;
- The relative number of each proton type is determined by the integrated signal intensities.

Signals of protons which associated with atoms of oxygen and nitrogen appear in a wide range of values  $\sigma$ . This is mainly due to the tendency of the protons to the formation of intra- and intermolecular hydrogen bonds, as well as the proton exchange. Chemical shifts of protons of ionizing compounds such as carboxylic acids or amino acids, exhibit a strong dependence on the solution of pH values.

## **PART III. MASS - SPECTROMETRY. THEORETICAL BASIS AND ANALYSIS**

### **Plan**

- Introduction. History of discovery of method.
- Scheme of mass spectrometer
- Enter the sample.
- Mechanisms of ionization.
- Types of ionization
- Types of mass analyzers
- Mass Detectors
- The mechanism of obtaining a mass spectrum
- Application
  - Qualitative analysis
    - Mass-spectrum
    - Determination of molecular weight
    - Determination of elemental composition
    - The interpretation of mass spectra
    - Search on databases
  - Quantitative analysis

## **Introduction. History of the discovery method.**

Mass spectrometry is based on the ionization of the molecules studied substance (analyte), followed by separation of the ion division-largest mass-to-charge ratio ( $m/z$ ) and detection.

Start an MS development J. on the experience. Thompson (1910), who studied the beams of charged particles, the separation of which the mass produced using electric. and magnesium. fields, and the spectrum was recorded on a photographic plate.

The first mass spectrometer constructed by Dempster in 1918, and the first mass spectrograph created by F. Aston in 1919; He also investigated the isotopy. composition of a large number of elements. The first serial mass spectrometer created Nir A. in 1940; his work laid the foundation for an MS isotope Direct connection of a mass spectrometer with a gas-liquid chromatograph (1959) made it possible to analyze complex mixtures of volatile compounds, and the compound with a liquid chromatograph using termoraspylit. apparatus (1983) - mixture volatility compounds.

1912 - Thomson creates the first mass spectrograph and obtains the mass spectra of molecules of oxygen, nitrogen, carbon monoxide, carbon dioxide and phosgene.

1913 - With the help of his mass spectrograph Thomson opens isotopes of neon: neon-20 and neon-22.

1923 - Aston is measured using a mass spectrometer the defect of mass.

1934 - Conrad uses mass spectrometry for the analysis of organic molecules.

1940 - Nir by preparative mass spectrometry identifies uranium-235.

1940 - Nir creates the first reliable source of electronic shock, using an ionization chamber.



1948 - Cameron and Egger created the first mass spectrometer with a time-of-flight mass analyzer.

1952 - Tal'roze and Lyubimov first observed signal  $\text{Me}^+\text{CH}_5^+$  in the ion source of electron impact at an elevated pressure of methane in the ionization chamber (in 1966 Munson and Field apply this discovery for analytical purposes and will create the ion source of chemical ionization).

1953 - Paul patents quadrupole mass analyzer and ion trap.

1956 - MakLaferti Golko and create the first gas chromatography-mass spectrometer.

1966 - Munson and Field create the ion source of chemical ionization.

1972 - Karatau and Mamyrin invented time-of-flight mass analyzer with focusing significantly improves the resolution of the analyzer.

1974 - The first liquid chromatography-mass spectrometer designed Arpino, Baldwin and MakLaferti.

1981 - Barber, Bordelais, Sedgwick and Taylor create ionizer with Fast Atom Bombardment (FAB)

1982 - first mass spectrum of the whole protein (insulin) using fast atom bombardment (FAB)

1983 - Forms and Bestaev invented termosprey.

1984 - LN Gall, then Fenn published works of electrospray method.

1987 - Karas, Bachmann, Bar and Hillenkamp invented ionization laser desorption assisted by matrix (MALDI).

1999 - Alexander Makarov invented an electrostatic ion trap.

Nobel Prize for the development of mass spectrometry

Francis William Aston (born Francis William Aston.) (September 1, 1877, Harborne, - November 20, 1945, Cambridge) - English physicist, member of the Royal Society of London (1921), corresponding member of the Academy of Sciences of the USSR (1924), winner of the Nobel Prize in Chemistry for the year 1922.

Aston constructed the first mass spectrometer and with his help discovered 213 stable isotopes of chemical elements, determined their relative prevalence. In 1925 he built a mass spectrograph of high resolving power, using it has made precise measurements of masses and masses of defects identified a number of isotopes.

Wolfgang Paul (Wolfgang Paul August 10, 1913, Lorenzkirche, the German Empire - December 7, 1993, Bonn, Germany) - German physicist, winner of the 1989 Nobel Prize in Physics, the (half of the prize together with Hans Dehmelt) "for the development of the method of retention of single ion" . He described the first device with a quadrupole analyzer.

Koichi Tanaka was born and raised in the city of Toyama. In 1983 he graduated from Tohoku University with an engineering degree. After Tanaka University he went to work at Shimadzu Corporation, which engaged in the development of mass spectrometers.

For mass spectrometric analysis the molecule which analyzed must be ionized and transferred into the gas phase (vaporized) by laser. However, such an action leads to the destruction of macromolecules, such as proteins.

In 1985, Tanaka found that by using thin metal powder in glycerol as a matrix macromolecular analyte may be ionized without destroying its structure. Tanaka used his discovery to mass spectrometry of proteins. In the same year, a technique has been patented and reported in 1987 at the annual conference of the Japan Society of mass spectrometry in Kyoto. The technique became known as the soft laser desorption (soft laser desorption, SLD). In 2002, Tanaka has received for his development of the Nobel Prize in Chemistry.

#### Criticism of the decision of the Nobel Committee

The decision to award the Nobel Prize for the development of mass spectrometry has drawn criticism. German scientists, Franz Hillenkamp and

Michael Karas in 1985 also developed a more sensitive method using a low molecular weight organic compounds as a matrix, they called matrix-assisted laser desorption / ionization (Matrix-Assisted Laser Desorption / Ionization, MALDI), which they, however, not used to ionize proteins to Tanaka's report. [3] Moreover, currently used for the study of protein MALDI, and not a technique SLD, developed by Tanaka.

John Bennett Fenn (June 15, 1917, New York, USA) - American analyst, professor, winner of the Nobel Prize in Chemistry in 2002 for the development of mass-spectrometric method for studying biological macromolecules, such as electrospray technique. Fenn began to work on the theme, for which he received the Nobel Prize, when he was 70 years old.

Using electrospray in the study of biological molecules has been widely used, for example, complex pharmacological test compounds.

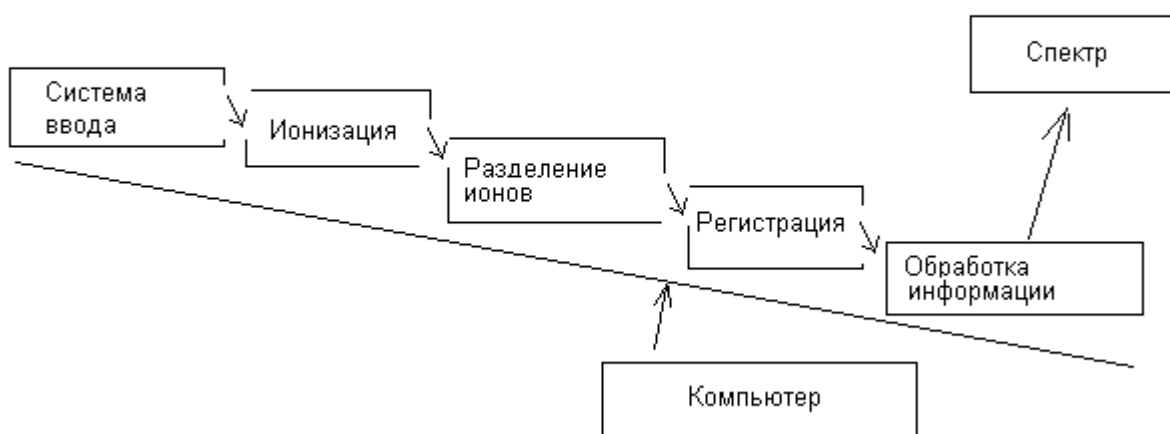

Pic. 16. Scheme of the mass spectrometer

### *Sample input*

The first step in the analysis is the introduction of the sample in the instrument, avoiding excessive influence on the vacuum. In the general method, called direct injection, a sample is placed on the end of the cylindrical rod (in a quartz crucible, at the cathode, or on a metal surface). The rod is introduced into the spectrometer, after passing through a vacuum lock, wherein the primary vacuum maintained intermediate between atmospheric pressure and the secondary vacuum device.

Other delivery systems can analyze components of the mixture in order to separate them on the corresponding device connected to a mass spectrometer.

- The container inlet
- Direct input
- Membrane input

#### GC-MS. Gas chromatography / mass spectrometry.

Apply the appropriate columns that allow you to enter directly into the sample source.

#### HPLC-MS. Liquid chromatography / mass spectrometry.

This combination is particularly useful for the analysis of polar compounds that are volatile or heat labile enough to be analyzed by gas chromatography in combination with mass spectrometry. The use of this method difficult complexity of producing ions in the gas phase from the liquid phase, which requires very specific interfaces, such as:

- Direct Liquid Introduction: mobile phase is sprayed, and the solvent is evaporated before the ion source device;

- Particle interface flow: mobile phase, which may have a flow rate of 0.6 ml / min, sprayed into desolvatation chamber so that only sample components is achieved in the neutral form in ion source device; This method is applicable to compounds with low polarity and with a molecular weight less than 1000 Da;

- Interface with a moving belt: mobile phase, which may have a flow rate of 1 ml / min, the strip applied to the surface, which is moving; after the solvent has evaporated, the pertinent components sequentially transferred to the ion source device, where they are ionized; this method is not very suitable for very polar or thermolabile substances.

Other types of connections (electrospray, thermospray, chemical ionization at atmospheric pressure) are treated as proper **methods of ionization** and should be considered in the **section of ionization** methods.

#### SFC-MS. Supercritical chromatography / mass spectrometry.

The mobile phase, which typically includes carbon dioxide in a supercritical state, passes to the gaseous state after passing the heated capillary between the column and the ion source.

#### CE-MS. Capillary Electrophoresis / Mass Spectrometry.

The eluent is introduced into the ion source, in some cases after addition of a further solvent, so that the flow rate reaches approximately several microliters per minute. This method is limited by the necessity of the use of small amounts of sample and volatile buffers.

### *Ionization mechanisms*

Protonation - ionization mechanism by which the molecule is attached to the proton, giving it the charge of 1+ per attached proton. Positive charges are usually located on the main parts of the molecule such as amines to form stable

cations. Peptides are often ionized by means of protonation. Protonation is carried out by MALDI, ESI and APCI.

Deprotonation - ionization mechanism in which the negative charge of 1 is obtained in the separation of a proton from the molecule. Such a mechanism is normally implemented with ionization MALDI, ESI and APCI and is very useful for the determination of acid samples, including phenols, carboxylic acids and sulfonic acids.

Cationization - ionization mechanism in which a charged complex is formed by coordination accession positively charged ion to the neutral molecule. In principle, protonation also falls within this definition, however the cationization considered accession ion other than proton such as alkali metal or ammonium. Furthermore, cationization applicable to molecules which are unable of protonation. Communication cations, unlike protons with molecule which covalent less, so the charge localized on the cation remains. This minimizes the blurring of charge and fragmentation of molecules. Cationization can also be performed with MALDI, ESI and APCI. Carbohydrates - the best material for this ionization mechanism, with the  $\text{Na}^+$  as the usual adjoin cation.

### *Types of ionization*

First thing you should do in order to obtain a mass spectrum, transform neutral molecules and atoms that make up any organic or inorganic substance, in the charged particles - ions. This process is called ionization and variously implemented for organic and inorganic substances.

The second necessary condition is the transfer of ions in the gas phase part in the mass spectrometer vacuum. High vacuum ensures smooth movement of ions in the mass spectrometer, and in his absence the ions recombine and dissipate (turn back to the uncharged particles).

Conventionally, ionization methods of organic materials can be classified into phases, which are substances before ionization.

The gas phase:

- electron ionization (EI)
- chemical ionization (CI)
- electron capture (EC)
- ionization in an electric field (FI)

Liquid phase:

- termosprey
- ionization at atmospheric pressure (AP)
- Electrospray (APESI)
- chemical ionization at atmospheric pressure (APCI)
- photoionization at atmospheric pressure (APPI)

Solid phase:

- direct laser desorption - mass spectrometry (LDMS)
- Matrix-assisted laser desorption / ionization (MALDI)
- mass spectrometry of secondary ions (SIMS)
- fast atom bombardment (FAB)
- an electric field desorption (FD)
- plasma desorption (PD)
- ionization in inductively coupled plasma (ICP)

- thermal ionization or surface ionization
- ionization of in a glow discharge and spark ionization of (see. Spark)
- ionization in the laser ablation process

In inorganic chemistry for analysis the elemental composition used rigid ionization methods, as the binding energy of atoms in solids is much larger and much more stringent methods must be used to break these bonds and get ions.

Historically, the first ionization methods have been developed for the gas phase. Unfortunately, many organic substances impossible to evaporate, that is converted into the gas phase without decomposition. This means that they can not be ionized by electron impact. But among these substances almost everything that is living tissue (proteins, DNA, and so on. D.), Physiologically active substances, polymers, that is all that is of particular interest today.

Mass spectrometry has not stood still, and the last years special ionization methods such organic compounds have been developed. Today mainly used, two of them - ionization of at atmospheric pressure, and its subspecies - Electrospray (ESI), chemical ionization at atmospheric pressure (APCI) and photoionization at atmospheric pressure (APPI), and ionization of by laser desorption assisted matrix (MALDI ).

#### Electronic stroke or electron ionization

Historically, this first method the ionization of organic compounds. He remains the most popular to date.

The real impact of electrons on the molecule does not occur. An electron flying near the molecule, it excites an electron shell. Own electrons of the molecule move to higher orbitals, and can leave the molecule. In this regard, most currently used term electron ionization.



An electron beam is generated by the cathode (wire or plate of tungsten or rhenium) and 12-70 accelerating potential in the direction of the anode. The substance in the gas phase (pressure  $10^{-5}$  -..  $10^{-6}$  mm Hg) is reacted with electrons and ionized. Formally, the equation of the ionization process can be represented by:

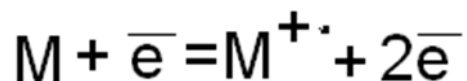

The result is a molecular ion  $M^{+\cdot}$ . It is odd electron ion, that is the radical cation. He, in turn, can break into smaller fragments. ionization efficiency is very low. Actually ionized 1: 10,000 molecules of the sample. In spite of this very great sensitivity of the method. For spectrum needed nano- and picogram quantities of sample.

An important parameter is the energy of ionizing electrons. The ion current reaches a maximum at an electron energy of 50 eV. Standard mass spectra EI should take off from the ionizing electrons with an energy of about 70 eV.

#### *Chemical ionization of at atmospheric pressure*

Chemical ionization method (chemical ionization) is based on the ionization of analyte molecules, as a result of ion-molecule interactions present in the source reagent gas ions. As the reactant gases using hydrocarbons (methane, isobutane, isopentane), ammonia (for selective ionization of alcohols and amines as the nucleophilic agent), water, tetramethylsilane and a number of other gases that provide acid-base interactions, as well as the noble gases, N<sub>2</sub>, CO, CO<sub>2</sub>, NO, O<sub>2</sub> and others to carry out redox reactions (recharge). Processes occurring in the chemical ionization are the following reaction sequence.

1. The formation of primary ions of the reactant gas in IE (electron energy of 70-200 eV). For example, these ions are produced from methane:  $CH_4 + e^- \rightarrow [CH_4]^+, [CH_3]^+, [CH_2]^+$ .

2. Formation of secondary ions. With increasing pressure in the source of clashes between the primary ions and neutral molecules of reactant gas, and these secondary ions are formed:

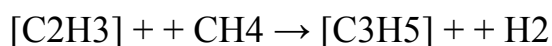
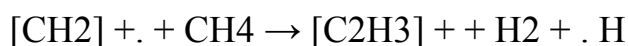
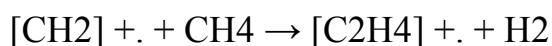
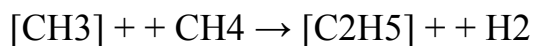
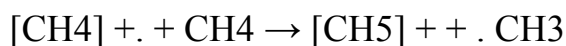

At a pressure of 1 Torr, the reagent gas plasma is 95% of the ions  $[\text{CH}_5]^+$ ,  $[\text{C}_2\text{H}_5]^+$  and  $[\text{C}_3\text{H}_5]^+$ .

3. Ion-molecule reaction with the analyte molecules and secondary ions, which occur with the introduction of 0.1% substance in plasma of the reactant gas. For example, in a plasma of methane reagent gas which contains Methoni ions  $[\text{CH}_5]^+$ , are the most potent 10 proton donor can be either proton transfer from the secondary ion per molecule and splitting off a hydride ion from the molecule and its transfer to the secondary ion .

Jonah  $[\text{BH}_2]^+$  are protonated by molecules (earlier they were called pseudomolecular ions). Jonah is  $[\text{B}]^+$  is often called quasimolecular. Both of these ions may undergo further disintegration:  $[\text{BH}_2]^+ \rightarrow [\text{B}]^+ + \text{H}_2$ ,  $[\text{BH}_2]^+ \rightarrow [\text{A}]^+ + \text{C}$ ,  $[\text{B}]^+ \rightarrow [\text{A}]^+ + \text{D}$ . The probability of protonation substrate molecule depends on comparison of its proton affinity and reactant gas. The higher proton affinity for the substrate, the more likely its protonation. It should be noted that the chemical ionization is a "soft" ionization method: internal energy of the ions formed in this case is much lower than the electron ionization. Thus ions which formed through the addition or elimination of a proton decompose slightly (although there are examples of rather intense fragmentation) and chemical ionization mass spectra peaks preferably comprise ions  $[\text{M} + \text{H}]^+$  or  $[\text{M}-\text{H}]^+$ .

*MALDI (matrix-assisted laser desorption / ionization)*

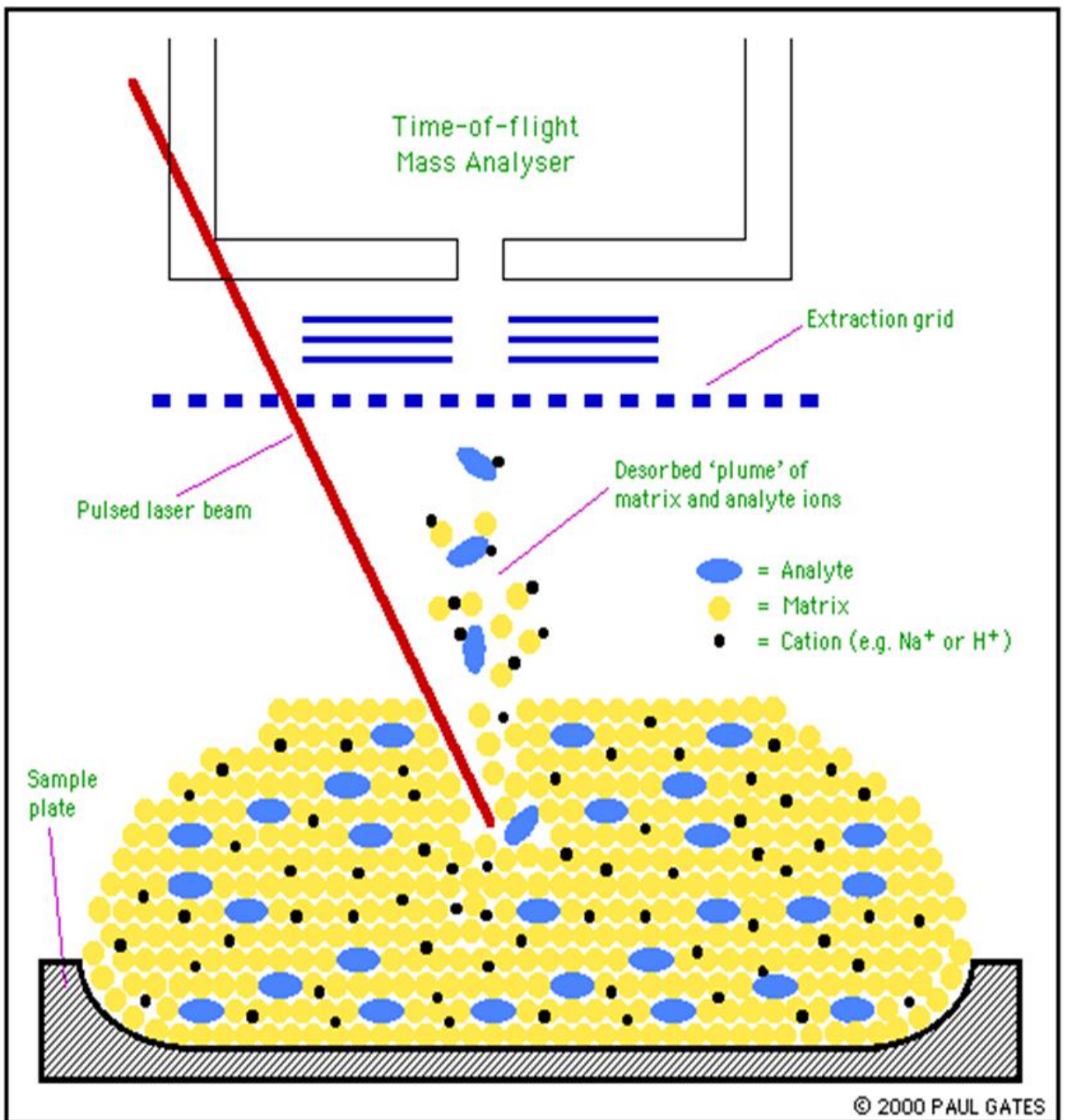

*Pic. 17. Scheme of MALDI*

Desorption method of "soft" ionization caused by exposure to laser pulses by a matrix with the analyte. The matrix is a material whose properties cause destructive lowering properties of laser radiation and ionization of the analyte. MALDI mass spectrometry is widely used for its analysis of non-volatile

macromolecular compounds (peptides, proteins, carbohydrates, oligonucleotides, etc.).

It is considered that the substance used as the matrix must meet the following basic requirements:

- 1) have a high extinction coefficient at the laser wavelength;
- 2) have the ability to ionization of neutral molecules of the analyte by transferring the charge or charged particles;
- 3) have good solubility in the solvents used in the sample preparation process;
- 4) to be chemically inert with respect to analyte;
- 5) have a low volatility and thermal stability.

It should indicate the selectivity in selecting the matrix compounds for the class of analytes. This is largely determined by the different nature of the formation of analyte ions mechanisms. Usually the dominant process in their formation is secondary ionization processes, namely the ion-molecule interaction between the matrix ions and analyte by molecules. In other words, the secondary ionization can occur due to processes such as proton transfer, a charged particle in the form of electrons, metal cations. For example, there is a widespread group of acidic matrices for analysis of proteins and peptides: 2,5-dihydroxybenzoic acid, various cinnamic acid derivatives, etc. Peptides and proteins tend to have high values of the proton affinity of 900 kJ / mol or more.. . These values exceed the value of the proton affinity of the compounds of the matrix, whereby the reaction of proton transfer is exothermic:



Another way of formation of ions occurs by electron transfer, the end result of which is the formation of molecular radical cation:

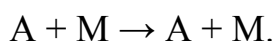

This is the most an effective way for the formation of positive ions nonpolar compounds with low values of the ionization energy.

### Mass-analyzer

Mass-analyzers - device for spaces. or temporal separation of ions with different  $m/z$  values in magn. or electric. fields or combinations thereof. There are static and dynamic analyzers. Static ions are separated in a permanent and virtually unchanging during their movement through the analyzer magnesium fields.

Ions with different  $m/z$  values in a moving analyzer along different trajectories and are focused at different locations or photographic plate or sequentially to the detector slit smooth change resulting electric and magnetic field analyzer. In dynamic analyzers separation of ions occurs under the influence of pulsed electric fields or radio frequency with a period of change smaller or equal to the time of flight of ions through the mass analyzer.

The resulting ions by ionization using an electric field transferred to the mass analyzer. There begins the second stage of the mass spectrometric analysis - sorting by mass ions (more precisely in relation to the weight of the charge, or  $m/z$ ). The following types of mass analyzers:

#### Continuous mass analyzers:

- The magnetic mass analyzer
- Mass-analyzer with crossed magnetic and electrostatic fields
- The quadrupole mass-analyzer
- Impulse mass analyzers:
- Time of flight mass analyzers
- Ion Trap

- The quadrupole linear trap
- Ion-cyclotron trap
- Mass-analyzer ion cyclotron resonance Fourier transform
- Orbitrap

The difference between continuous and pulsed mass analyzers is that in the first ions enter a continuous flow, and the second - in portions at regular intervals.

The mass spectrometer may have two mass analyzer. Such a mass spectrometer called tandem. The tandem mass spectrometers are used, usually together with a 'soft' ionisation techniques in which fragmentation does not occur ions analyzed molecules (molecular ion).

Thus, the first mass-analyzer analyzes the molecular ions. Leaving the first mass analyzer, molecular ions are fragmented by collisions with the molecules of the action of an inert gas or laser light, and then analyzed fragments in the second mass analyzer.

The most common configurations of tandem mass spectrometers are quadrupole-quadrupole and quadrupole-time of the span.

### **Types of MS-MS mass analyzers**

MS/MS в  
пространстве

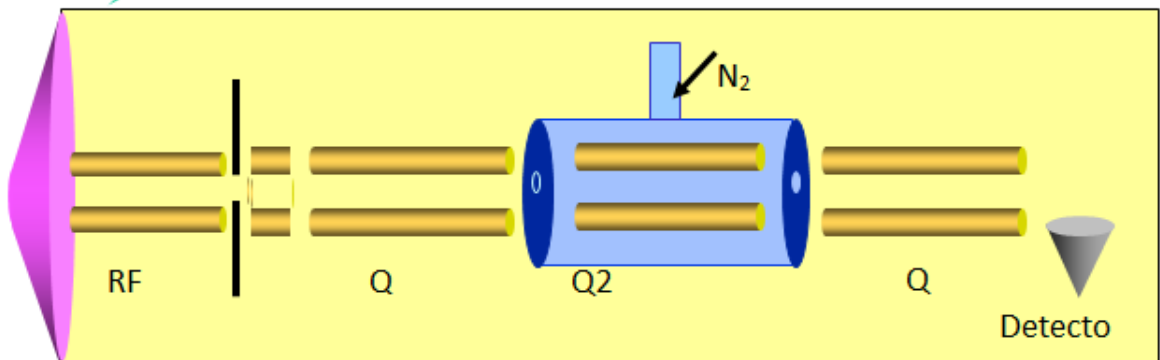

MS/MS во времени

Все ионы из источника

поступают в ловушку

ионы вещества

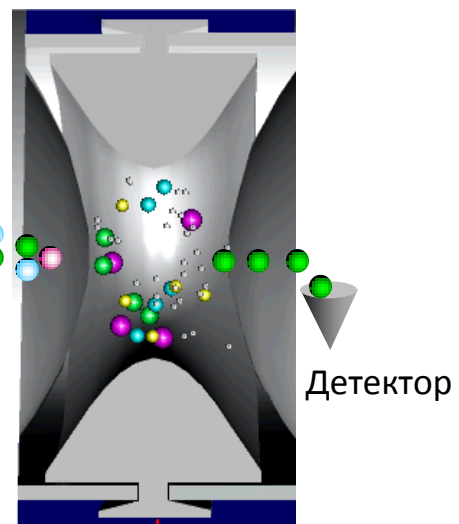

Ions are pass the way about which I have already spoken, and fall into the trap. TRAPPING: This trap captures, stores, filled them. It is filled because Coulomb forces tend to push the ions with the same charge of this

pan. And in this state they are captured is trapped for a long time - hours. This is different from the action of the quadrupole trap.

In a trap there are also neutral helium atoms in an amount several orders of magnitude superior ion concentration. This so-called gas damper. His presence has a positive effect on the safety of the ions and the sensitivity of the system. ZOOM MS / MS, Field. The voltage across the electrodes, and thus the field strength inside the trap can be made to vary widely, and the trap will work either as a trap or a sorter ions. DETECTION.

So in steps by changing the voltage on the walls and cover the pan can consistently make ions with small, medium and large mass leave the trap in the direction of the detector. However, the trap can work as a kind of mill ions. COLLISION So capturing and sorted by weight with respect to the charge of ions of the same type. You can program the respective supply voltage, which will generate an electromagnetic field so as to cause the ions to move quickly in the pan ions will collide with helium atoms and experience further fragmentation.

Thus, at the end of the process in the trap will be present the parent ion and daughter ions. After crushing processes detection is repeated. Thus trap allows to register the MS / MS spectra. The process can be repeated many times. Thus, in the ion traps can be repeated from Agilent MS / MS with the number of steps to 11, including automatically - 5 stages.





A.A. Makarov, *Analytical Chemistry*, v.72 (2000), No.6, p.1156-1162.

A.A. Makarov, *U.S. Pat. 5,886,346*, 1999.

$$\omega_z = \sqrt{\frac{k}{m/q}}$$

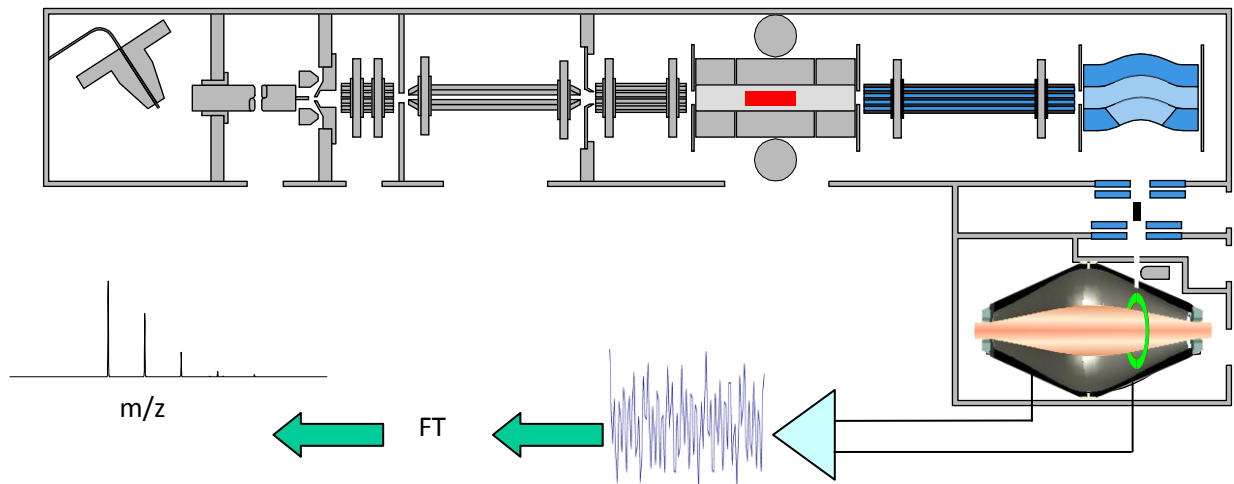
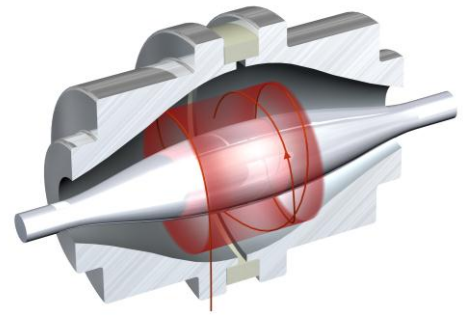

Thus, the last element of the described simplified mass spectrometer, a detector of charged particles. The first mass spectrometer used as a detector photoplate. Now used dynode secondary-electron multipliers in which ions falling on the first dynode, knocks him out of the electron beam, which in turn, getting the next dynode, knocked out of him even greater number of electrons, and so on.

Another variant - photomultiplier tubes that detect luminescence that arises during ion bombardment of the phosphor. In addition, using microchannel multipliers, systems such as diode arrays and collectors, collecting all the ions trapped in the given point in space (Faraday collectors).

### *Characteristics of mass spectrometers and mass spectrometric detection*

The most important technical characteristics of mass spectrometers are sensitivity, dynamic range, resolution, and scan speed.

The dynamic range (in mass spectrometry). If we analyze a mixture containing 99.99% of one compound or any element and 0.01% of any impurity,

we must be sure that properly define both. In order to be sure of determining components in this example, must have a range of linearity in the order of 4.

Modern mass spectrometers for analysis of organic characterized by a dynamic range of 5-6 orders of magnitude, and mass spectrometers for elemental analysis 9-10 orders. The dynamic range of 10 orders of magnitude means that the impurity in the sample will be visible even when it is 10 milligrams per 10 tons.

Resolution (resolving power) of mass spectroscopy - quantitative measure that characterizes the ability of analyzer to separate ions of adjacent mass or, in other words, to determine the precise mass ion.

For magnetic mass analyzer, for which the distance between the peaks of the mass spectrum does not depend on the mass of the ions, the resolution is a value equal to  $M / \Delta M$ . This value is typically determined at 10% peak height. For example, the resolution of 1000 means that the peaks from 100.0 and the masses. e. m. and 100.1 as well. e. m. separated from one another, that is, do not overlap up to 10% of the height.

For analyzers in which the separation between the peaks changes in the operating range of the masses (the greater the mass, the smaller the distance), such as quadrupole analyzers, ion trap, time-flight analyzers, strictly speaking, the resolution has a different meaning.

The resolution, defined as  $M / \Delta M$ , in this case the specific weight characteristic. It makes sense to characterize these mass analyzers, the width of the peaks, the value remains constant throughout the range of masses. This width of the peaks, typically measured at 50% of their height.

For these devices the peak width at half maximum equal to 1 is a good indicator means that a mass analyzer is able to distinguish between the nominal mass, characterized by one almost all its operating range.

Nominal mass or mass number called soon to accurate mass ion an integer in the scale of atomic mass units. For example, the hydrogen ion  $H^+$  is equal to the mass of 1.00787 a. e. m., and its mass number equal to 1. A mass analyzer such that, basically, the nominal weight is measured is called the low-resolution analyzers.

Ion traps in a narrow range masses can operate as a mass spectrometer of high resolution by providing a minimum separation of peaks spaced  $1/4$  a. e. m. of each other. Mass spectrometers with double focusing (magnetic and electrostatic), ion cyclotron resonance - Instruments medium or high resolution. Permissions of several thousand also can be achieved by using the time-flight mass analyzer.

Resolution is closely related to another important characteristic - precision mass measurements. A simple example can illustrate the significance of this characteristic. Molecular mass ions of nitrogen and carbon monoxide ( $CO$ ) and constitute 28.00615 a. e. m. and 27.99491 a. e. m., respectively (both are characterized by a mass number of 28). These ions will be recorded by the mass spectrometer apart at a resolution of 2500, and the exact weight value will give the answer - which of the gas logs. An accurate measurement of mass is available on double focusing instruments and tandem.

The most important characteristic in the analysis of organic compounds - this sensitivity. In order to achieve the greatest possible improvement in the sensitivity of the signal to noise ratio by resorting to the detection of certain selected ions. The gain in sensitivity and selectivity while enormous, but when using a low resolution instrument has to sacrifice another important parameter - authenticity.

In fact if you record only one peak characteristic of the entire mass spectrum, you'll need a lot more work to do to prove that this peak corresponds exactly to a component which you are interested in. How to solve this problem? Use the highest resolution on the devices with a dual focus, which can achieve a

high level of reliability without sacrificing sensitivity. Or using tandem mass spectrometry, where each peak corresponding to a single ion can be confirmed by the mass spectrum of the daughter ions.

Thus, an absolute record for the sensitivity of an organic gas chromatography-mass spectrometer with high resolution double focusing.

According to the characteristic of the combination of the sensitivity of reliably determining the components behind appliances of high-resolution are ions traps. Classic quadrupole new generation of devices have improved performance through a number of innovations in Applied on them, for example, the use of curved quadrupole prefilter preventing neutral particles from entering the detector and hence reduce noise.

The scanning speed. Mass analyzer passes ions with a certain mass and charge ratio at a certain time. In order to analyze all ions it should scan, that is, the parameters of its fields are in a given period of time to go through all the values that are required for the transmission to the detector of ions of interest.

This speed of deployment field called scanning speed and must be as much as possible (thus the scan time should be as small as possible), since the mass spectrometer should have time to measure the signal in a short time, for example during the exit of the chromatographic peaks, which can be 1 second.

The slowest mass analyzer is a magnet, its minimum scan time without much loss of sensitivity is a fraction of a second (MAT 95XP).

The quadrupole mass analyzer can expand range of tenths of a second (TSQ 7000, TRACE DSQ), and ion trap even faster (POLARIS, LCQADVANTAGE, LCQDECA). But the fastest mass analyzer is a time-of-flight (TEMPUS). It is able to record mass spectra at a rate of 40,000 per second.

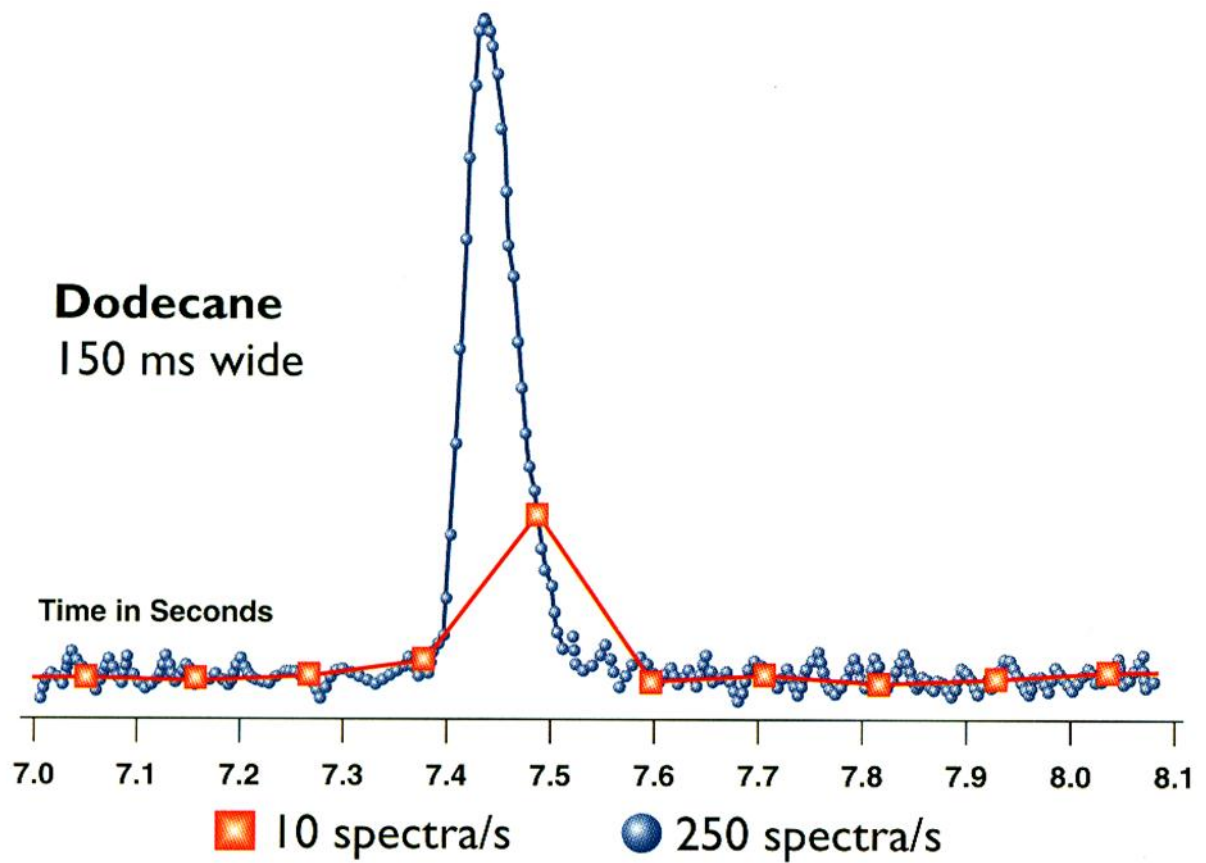

### *Application*

- Chemistry
- Biology
- Medicine
- Proteomics
- Physics
- Geology
- Space exploration
- Doping control
- Forensics

- Environment
- Examination of art
- Monitoring of industrial processes
- Archaeology

The development of new medicinal products for human salvation from a previously incurable diseases and drug production control, genetic engineering and biochemistry, proteomics. Without mass spectrometry unthinkable control of illegal distribution of narcotic and psychotropic drugs, forensic and clinical analysis of toxic drugs, explosives analysis.

Elucidation of the origin is very important to address a number of issues: for example, the determination of the origin of explosives helps to find terrorists, drug - to fight their spread and to block the path of traffic.

The economic security of the country is more reliable if the customs authorities are not only confirmed by the analysis in cases of doubt, the country of origin of the goods, but also to comply with the declared type and quality. And the analysis of oil and petroleum products is necessary not only to optimize the processes of refining or geologists to search for new oil fields, but also to identify those responsible for the spill of oil spills in the ocean or on the land.

In the era of "chemicalization of agriculture" has become a very important question about the presence of trace amounts of chemicals used (eg, pesticides) in food. The miniscule amounts of these substances can cause irreparable harm to human health.

A number of technological (not existing in nature, but emerged as a result of the industrial activity of man) substances are supertoxicants (having toxic, carcinogenic or harmful to human health effects in extremely low concentrations). An example is the well-known dioxin.

Existence of nuclear power is impossible without mass spectrometry. With its help determine the degree of enrichment of fissile materials and their purity.

Of course, and medicine is not without mass spectrometry. Isotope Mass Spectrometry of carbon atoms is used for direct medical diagnosis of human Helicobacter pylori infection is the most reliable of all the methods of diagnosis. Also, mass spectrometry is used to determine the presence of drugs in the blood of athletes.

It is hard to imagine the area of human activity, where there was no place of mass spectrometry. Let's list the areas: analytical chemistry, biochemistry, clinical chemistry, general chemistry and organic chemistry, pharmaceuticals, cosmetics, perfumes, food processing, chemical synthesis, petrochemistry and nefteperarabotka, control of the environment, the production of polymers and plastics, medicine and toxicology, forensics, doping control, control of narcotics, control of alcoholic beverages, geochemistry, geology, hydrology, petrography, mineralogy, geochronology, archeology, nuclear industry and energy, the semiconductor industry, metallurgy.

### *Qualitative analysis*

#### Mass spectrum

Mass spectrum is a two-dimensional representation the intensity of signal (y-axis) from  $m / z$  (abscissa). The peak intensity reflects the quantity of ions of one species with the corresponding ratio  $m / z$ , which were obtained from the analyte in the ion source. The ratio of mass to charge ratio is a dimensionless quantity, because it is calculated from the mass of the dimensionless number,  $m$ , of the ion and the number of its elementary charge,  $z$ . The number of elementary charges are often, but not necessarily, sooner zero. Subject to observation of singly charged ions ( $z = 1$ ),  $m / z$  directly reflects the scale of the mass number  $m$ . However, there may be circumstances when two, three or more charged ions can be produced from the analyte, depending on the ionization method used.

The distance between the peaks on axis has a value of neutral large loss of the ion  $m/z$  value during the formation of the fragment ion at a lower value  $m/z$ .

Often, but is not necessary the highest peak at  $m/z$  obtained from the non-ionized molecules - molecular ion  $M^+$ . The peak of the molecular ion is usually accompanied by a number of peaks with lower  $m/z$  value caused by the fragmentation of the molecular ion, called fragment ions. The most intense peak in the mass spectrum is named the main peak. In most cases, presentation of mass spectral data of intensity of the main peak is normalized to 100% relative intensity. It helps to make mass spectra more comparable. The intensities are independent of the absolute values of the number of ions detected by the detector. However, in the older literature, the spectra were normalized to the sum of all measured intensities, or presented normalized to the all sum of the intensities of above mentioned, for example  $m/z = 40$ .

### Interpretation of the mass spectrum

Spectra usually transcribe from larger ratio  $m/z$  to smaller, because large fragments are usually the most informative. Perhaps, for them only a very limited number of ways to education, while small can occur in various ways and extract analytically useful information about them from the spectrum is much more difficult.

### Molecular ion

Starting the interpretation of the spectrum should with the establishment of a molecular ion peak, that is peak corresponding ionized but not disintegrated parent molecule. Usually it is designated by the letter  $M$ . The relative intensity of the peak  $M$  allows us to make certain assumptions about its structure and accessories analyte to one or another class. The mass  $M$  is the mass of ionized molecules, net weight of a single electron. The probability of the formation of the molecular ion is more for small simple molecules. As the number of atoms in the molecules increases the probability of fragmentation ion  $M^+$ . Such stable group as



a benzene ring on the contrary, contribute to the formation of molecular ion. In fact, the molecular mass can only have discrete values that immediately severely limits the number of possible structures and more detailed analysis of the spectrum in the molecular ion peak allows to obtain a whole series of additional information. We give a simple example. Natural bromine consists of two isotopes  $^{79}\text{Br}$  and  $^{81}\text{Br}$  ratio of 1: 1. Therefore, the molecular ion of any compound which contains one bromine atom, gives the mass spectrum two peaks of equal intensity, differing by two atomic mass units. This doublet in the spectrum is very characteristic and immediately indicates the presence of test compounds is only one bromine atom. If there were two bromine atoms, the respective ions would give a peak in the triplet with the distance between the two components in mass units and an intensity ratio of 1: 2: 1.

However, when choosing a peak of molecular ion should be remembered that a reduction in the value of  $M$  from 5 to 14 or from 21 to 25 amu, leading to the emergence of intense ion peaks, highly unlikely. If the spectrum peaks are still present, the most intense peak is taken as  $M$  molecular apparently, incorrectly selected, or the sample contains impurities. For example, if the mass spectrum of pure compounds of the heaviest ion has a mass of 120 and following it - 112, ion 120 - not molecular, and fragmented. Furthermore, if the peak intensity  $M + 2$  is less than 3% of the peak of intensity of  $M$ , the compound does not contain chlorine, bromine, sulfur and silicon, which is associated with the nature of the isotopes of these elements.

Next, we analyze the fragments. Molecular ion splits into two particles: the charged and neutral. The latter is often highly stable small molecule such as  $\text{H}_2\text{O}$ ,  $\text{CO}$ , etc. These fragments are neutral, but can be identified indirectly - on the mass difference and the charged molecular ion fragment. The latter is often described as a difference, for example:  $M - \text{H}_2\text{O}$ , or  $M - 18$ ;  $M - \text{CO}$ , or  $M - 28$ ;  $M - \text{CH}_3$ , or  $M - 15$ ;  $M - \text{H}_2\text{C} = \text{C} = \text{O}$ , or  $M - 42$ , etc. The composition of such large fragments usually easily identified as composition number of variants of small fragments is very

small. For example, for conventional organic compounds  $M-18$  - is always  $M-H_2O$ . A intense ion signal  $M - H$  ( $M-1$ ) means not only the presence of the labile hydrogen atoms, but no other labile groups in this position. In the high-mass region are important practically all the peaks, even when their intensity is less than 1%. Fragments, which arise directly from the collapse of the molecular ion, can be somewhat, because the decay can occur in several ways.

Primary fragments are subjected to further disintegration. So there are a series of ions corresponding to the specific ways the disintegration or fragmentation of the molecular ion.

#### The fragmentation of the molecular ion.

The fragmentation of the molecular ion can go in different directions, due to the structure of the molecule and the ionization method. Ionization process is not a simple removal of an electron from one of the links. In fact, the charge incurred so rapidly redistributed on communications that occur during the ionization of simultaneous weakening of bonds but one of the links can be attenuated to a greater extent than others. With increase of the energy of ionizing agents initially torn weakest links, and at high energies are increasing the probability of rupture of a stronger relationship, and there are all kinds of fragment ions. Quantitative characteristic of fragment ions is their potential appearance, that is the minimum energy of the ionizing agent, which is sufficient to form the corresponding fragment ion. The presence of of fragment ions along with other ions and molecular makes mass spectrum is characteristic for a given substance. Types of of fragment ions, their relative intensities are given in special catalogs or atlases mass spectra, which are used to identify the analytes. Many substances give the new group ions, the origin of which can not be explained by a simple break links in the molecular ion. They arise from the rearrangement of atoms during dissociation. This means that fragmentation can be accompanied by the formation and rupture of some other linkages. Very often there are the rearrangement with migration of a

hydrogen atom. A characteristic feature of the new ions is the constancy of the relative intensity when the pressure or decreasing the energy of ionizing agents.

Descriptions the formation of mechanisms are based on various assumptions, but new ions are often specific to each group of compounds and, therefore, are important for deciphering the mass spectra.

Metastable ions, as well as new ions, are a kind of fragmentation. If the decay of molecular ion occurs in the path between the outlet and the inlet of the mass analyzer (time of about  $10^{-6}$ ), the metastable ions observed in the mass spectrum. They typically give peaks with a fractional value of the mass and with a characteristic appearance, diffuse, diffuse, low intensity.

Blurring of peak due to the fact that the disintegration of the primary ion flows in different points of its movement trajectory with different amounts loss of kinetic energy. At high energies, the ionization may lose a molecule of two or more electrons to produce ions with a charge of 2 or higher (multiply charged ions). Such ions will have a ratio of  $m / z$  equal to  $m / 2$ ,  $m / 3$  etc. If the value of mass  $m$  is odd, in the mass spectrum will be recorded ions with fractional  $m / z$ , which allows to distinguish between multiply charged ions from singly.

Quite often doubly charged ions are formed from aromatic compounds. These intensities have considerable in compounds with stable circular (cyclic) structure, especially if it contains the heteroatoms nitrogen, oxygen. In the hetero atoms in the molecular ion is localized positive charge that facilitates the removal of an electron from the next without ion dissociation. Multiply charged ions can also undergo fragmentation.

The probability of the formation of negative ions in the thousands of times smaller than the formation of positive ions. Mass spectrum of negative ions is much poorer, but it can give important information about the structure of molecules. These ions are formed as a result of: a resonant electron capture molecule ( $AB + e^- \rightarrow AB^-$ ), dissociative resonance capture ( $AB + e^- \rightarrow A^- + B$ ),

ion-molecule reactions ( $AB + C^- \rightarrow ABC^-$ ) and molecules decay into a pair of ions ( $AB \rightarrow A^- + B^+$ ).

In the mass spectra of organic compounds, the relative intensity of the molecular ion peaks are accompanied by a "satellite" in the area of larger mass numbers. This is due to the fact that the "biological" elements (C, H, O, N, S) are more common in nature light isotopes. Peaks of isotope ions have masses at 1, 2, 3, etc. amu is greater than the primary molecular ion. The isotope peaks in the mass spectra facilitate the assignment of peaks of molecular ions, the establishment of the gross formula of substance.

These general rules are usually very specific in establishing qualitative correlation between the structure of the isomers of any such connections and allow you to select the characteristic peaks and characteristic loss underlying the identification of unknown compounds.

Art of decoding spectrum largely consists in the ability of a large number of peaks highlight those which are linked to certain series - a sequence of ion source fragmentation. When such a series identified restore a picture of decay and therefore the structure of the analyte is already much easier, particularly if the researcher has general information about the characteristic fragmentation pathways of compounds of this class.

Regularities of molecular fragmentation:

- the probability of fragmentation increases with the weakening of the tear bonding strength
- primarily single C-C bond are burst, while multiple (double, triple) hardly affected
- C-C bond tear easier than C-H bond
- in the presence of carbonyl groups are broken links "on both sides" of it

- the relative intensity of fragment ions increases with the possibility of stabilization due to the separation of solid neutral fragments as the H<sub>2</sub>O, CO, C<sub>2</sub>H<sub>2</sub>, of HCN, C<sub>2</sub>H<sub>4</sub>, CO<sub>2</sub>.

### *Quantitative Analysis*

Quantitative analysis is based on determining the peak intensities of ions with certain  $m/z$  values. It is carried out chromatography-mass spectrometry, or direct entry system. To improve the accuracy are used internal standards, which are used as labeled compound or compounds similar in structure to the studied such homologues. In the last case is necessary to construct the calibration curves. The measurement of the test substance is carried out based on the amount of added standard relative peak areas corresponding to the analyte and the internal standard. The best results are obtained by the use of labeled compounds; thus is not necessary to construct calibration curves.

Quantitative determination of the volatility substances is carried out in the system of direct input of detecting one or uncompensated ions characteristic of the test compound. With the gradual increase of the evaporator temperature, the evaporation and partial fractionation of analytes. So for each substance is obtained evaporation curve, the area under a swarm directly proportional to the amount of the compound introduced into the mass spectrometer. The advantage of the method - no need for pre-treatment of the test substances. In the study of compounds with electrophorus groups, isomeric organic molecules, polymers, azo dyes and biologically active substances used mass spectrometry negatively charged ions. These ions have a smaller internal energy margin than positively charged ions, so the mass spectra allowed intense peaks of molecular ions and fragment ions of small amounts.

## BASIC REFERENCES

1. Medical chemistry: educational and methodical recommendations / A.G. Kaplaushenko, I.A. Iurchenko, B.A. Varinskiy, M.A. Shcherbak, Yu.N. Kucheryavyi. – Zaporozhye, 2014. – 263 p.
2. Medical chemistry: textbook for students of higher medical educational institutions of the III-IV accreditation levels / V.A. Kalibabchuk, V.I. Halynska, V.I., Hryshchenko [et al.]. – Kyiv : Medicine Publishing, 2010. - 223 p.
3. Fundamentals of Medicinal Chemistry / Gareth Thomas, John Wiley & Sons – First Edition. – December, 2003. – 285 p.
4. An Introduction to Medicinal Chemistry / Graham L. Patrick. – Oxford University Press – 4th Edition. – October, 2009. – 776 p.

## SUPPORTING REFERENCES

1. Principles of Bioinorganic Chemistry/ Stephen J. Lippard, Jeremy M. Berg, University Science book, 2005, 411 p.
2. Biological Inorganic Chemistry: Structure and Reactivity 1st Edition. Harry B. Gray, Edward I. Stiefel, Joan Selverstone Valentine, Ivano Bertini. University Science book, 2007, 731 p.
3. Biological Inorganic Chemistry, Second Edition: A New Introduction to Molecular Structure and Function 2nd Edition. Robert R. Crichton . Elsevier. 2012, 447 p.
4. Foye's Principles of Medicinal Chemistry 7th Edition. David A. Williams. Lippincott Williams & Wilkins, 2013. 1500 p.
5. Principles of Colloid and Surface Chemistry, Third Edition, Revised and Expanded (Undergraduate Chemistry: A Series of Textbooks) 3rd Edition. Paul C. Hiemenz, Raj Rajagopalan. Taylor & Francis. 1997, 650 p.
6. Physical Chemistry, 9th Edition 9th Edition. Peter Atkins , Julio de Paula. Oxford University Press. 2010. 959 p.
7. Handbook of Surface and Colloid Chemistry, Fourth Edition. K. S. Birdi. CRC Press. 2015. 708 p.